

Measurement Guide

Agilent Technologies ESA-E Series Spectrum Analyzers cdmaOne Measurement Personality

This manual provides documentation for the following instruments:

ESA-E Series

E4402B (9 kHz - 3.0 GHz)

E4404B (9 kHz - 6.7 GHz)

E4405B (9 kHz - 13.2 GHz)

E4407B (9 kHz - 26.5 GHz)



Agilent Technologies

Manufacturing Part Number: E4402-90008

Printed in USA

August 2000

© Copyright 2000 Agilent Technologies, Inc.

Notice

The information contained in this document is subject to change without notice.

Agilent Technologies makes no warranty of any kind with regard to this material, including but not limited to, the implied warranties of merchantability and fitness for a particular purpose. Agilent Technologies shall not be liable for errors contained herein or for incidental or consequential damages in connection with the furnishing, performance, or use of this material.

Warranty

This Agilent Technologies instrument product is warranted against defects in material and workmanship for a period of three years from date of shipment. During the warranty period, Agilent Technologies Company will, at its option, either repair or replace products that prove to be defective.

For warranty service or repair, this product must be returned to a service facility designated by Agilent Technologies. Buyer shall prepay shipping charges to Agilent Technologies and Agilent Technologies shall pay shipping charges to return the product to Buyer. However, Buyer shall pay all shipping charges, duties, and taxes for products returned to Agilent Technologies from another country.

Agilent Technologies warrants that its software and firmware designated by Agilent Technologies for use with an instrument will execute its programming instructions when properly installed on that instrument. Agilent Technologies does not warrant that the operation of the instrument, or software, or firmware will be uninterrupted or error-free.

LIMITATION OF WARRANTY

The foregoing warranty shall not apply to defects resulting from improper or inadequate maintenance by Buyer, Buyer-supplied software or interfacing, unauthorized modification or misuse, operation outside of the environmental specifications for the product, or improper site preparation or maintenance.

NO OTHER WARRANTY IS EXPRESSED OR IMPLIED. AGILENT TECHNOLOGIES SPECIFICALLY DISCLAIMS THE IMPLIED WARRANTIES OF MERCHANTABILITY AND FITNESS FOR A PARTICULAR PURPOSE.

EXCLUSIVE REMEDIES

THE REMEDIES PROVIDED HEREIN ARE BUYER'S SOLE AND EXCLUSIVE REMEDIES. AGILENT TECHNOLOGIES SHALL NOT BE LIABLE FOR ANY DIRECT, INDIRECT, SPECIAL, INCIDENTAL, OR CONSEQUENTIAL DAMAGES, WHETHER BASED ON CONTRACT, TORT, OR ANY OTHER LEGAL THEORY.

Where to Find the Latest Information

Documentation is updated periodically. For the latest information about Agilent ESA Spectrum Analyzers, including firmware upgrades, software upgrades, application information, and product information, please visit the Internet URL listed below.

<http://www.agilent.com/find/esa/>

Safety Information

The following safety notes are used throughout this manual. Familiarize yourself with these notes before operating this instrument.

WARNING	Warning denotes a hazard. It calls attention to a procedure which, if not correctly performed or adhered to, could result in injury or loss of life. Do not proceed beyond a warning note until the indicated conditions are fully understood and met.
---------	---

CAUTION	Caution denotes a hazard. It calls attention to a procedure that, if not correctly performed or adhered to, could result in damage to or destruction of the instrument. Do not proceed beyond a caution sign until the indicated conditions are fully understood and met.
---------	---

WARNING	This is a Safety Class 1 Product (provided with a protective earth ground incorporated in the power cord). The mains plug shall be inserted only in a socket outlet provided with a protected earth contact. Any interruption of the protective conductor inside or outside of the product is likely to make the product dangerous. Intentional interruption is prohibited.
---------	--

WARNING	No operator serviceable parts inside. Refer servicing to qualified personnel. To prevent electrical shock do not remove covers.
---------	--

CAUTION	Always use the three-prong AC power cord supplied with this product. Failure to ensure adequate grounding may cause product damage.
---------	---

Contents

1. cdmaOne Use Model	
Use Model	1-2
Measurement Overview	1-3
The Fault Finding Process	1-4
Identifying Interfering Signals	1-6
Examples of Interference Signals	1-8
2. Preparing to Make cdmaOne Measurements	
cdmaOne Measurements	2-2
Basic Key Use	2-3
3. Making Basic cdmaOne Base Station Measurements	
Available Basic cdmaOne Measurements	3-6
Making the Channel Power Measurement	3-7
Purpose	3-7
Measurement Method	3-7
Measurement Hints	3-7
Making the Measurement	3-8
Results	3-10
Troubleshooting Hints	3-11
Making the Receive Channel Power Measurement	3-12
Purpose	3-12
Measurement Method	3-12
Measurement Hints	3-13
Making the Measurement	3-13
Results	3-17
Troubleshooting Hint	3-18
Making the Monitor Band/Channel Measurement	3-19
Purpose	3-19
Measurement Method	3-19
Measurement Hints	3-20
Making the Measurement	3-20
Results	3-22
Troubleshooting Hints	3-23
Making the Occupied Bandwidth Measurement	3-24
Purpose	3-24
Measurement Method	3-24
Measurement Hints	3-24
Making the Measurement	3-25
Results	3-27
Troubleshooting Hints	3-28
Making the Adjacent Channel Power Ratio (ACPR) Measurement	3-29
Purpose	3-29
Measurement Method	3-29
Making the Measurement	3-30
Results	3-32
Troubleshooting Hints	3-34
Making Return Loss Measurements	3-35

Contents

Purpose	3-35
Measurement Method	3-35
Making the measurement	3-35
Results	3-38
Troubleshooting Hints	3-38
Making Loss/Gain Measurements	3-39
Purpose	3-39
Measurement Method	3-39
Measurement Hints	3-39
Making the measurement	3-40
Results	3-41
Troubleshooting Hints	3-42
4. Making Advanced cdmaOne Base Station Measurements	4-2
Available Advanced cdmaOne Measurements	4-2
Making the Code Domain Measurement (Base Station Only)	4-3
Purpose	4-3
Measurement Method	4-3
Measurement Hints	4-3
Making the Measurement	4-4
Results	4-6
Troubleshooting Hints	4-7
Making the Modulation Accuracy (Rho) Measurement	4-8
Purpose	4-8
Measurement Method	4-8
Measurement Hint	4-8
Making the Measurement	4-9
Results	4-11
Troubleshooting Hints	4-12
Making the Spur Close (In Band Spurious) Measurement	4-13
Purpose	4-13
Measurement Method	4-13
Making the Measurement	4-13
Results	4-16
Troubleshooting Hint	4-17
Making the Out of Band Spurious Measurement	4-18
Purpose	4-18
Measurement Method	4-18
Measurement Hints	4-18
Making the Measurement	4-19
Results	4-21
Troubleshooting Hints	4-22
Making the Receiver Spurious (Rx Spur) Measurement	4-23
Purpose	4-23
Measurement Method	4-23
Measurement Hints	4-24
Making the Measurement	4-24
Results	4-27

Contents

Troubleshooting Hints	4-28
Making the Spurs at Harmonics Measurement	4-29
Purpose	4-29
Measurement Method	4-29
Measurement Hints	4-29
Making the Measurement	4-30
Results	4-31
Troubleshooting Hints	4-32
Making the Microwave Transmitter Power Measurement	4-33
Purpose	4-33
Measurement Method	4-33
Making the Measurement	4-33
Results	4-35
Troubleshooting Hints	4-35
Making a Microwave Spectrum Monitoring Measurement	4-36
Purpose	4-36
Measurement Method	4-36
Measurement Hints	4-36
Making the Measurement	4-36
Results	4-38
Making the Microwave Adjacent Channel Power Measurement	4-39
Purpose	4-39
Measurement Method	4-39
Measurement Hints	4-39
Making the Measurement	4-40
Results	4-41
Troubleshooting Hints	4-41

1 cdmaOne Use Model

Use Model

Figure 1-1 Cellular Site Components

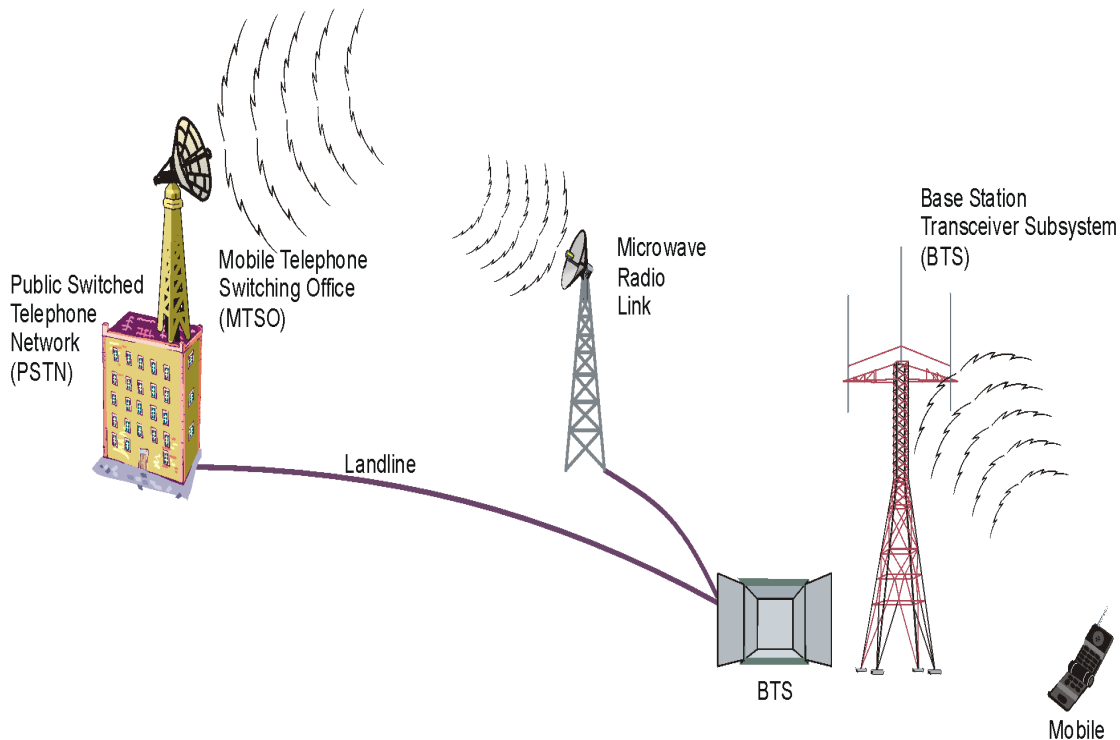

b178b

Wireless Digital communications systems are made up of five parts: a central phone switching system, a microwave or landline link, a base transceiver station (BTS), an antenna and preamplifier system, and the air interface with the mobile device. The measurement personality is designed to verify the satisfactory operation of the base station system which includes the microwave link, the base transceiver station, the antenna and preamplifier system, and the air interface with the mobile device. The measurements in this guide are divided into chapters according to the subsystems that each tests.

Measurement Overview

When troubleshooting a digital communications system, use the following flow chart to help determine which test to perform on what system subsection. System failures are generally defined as reduced transceiver site coverage and capacity, or handoff errors.

Figure 1-2 Measurements and System Interrelationship

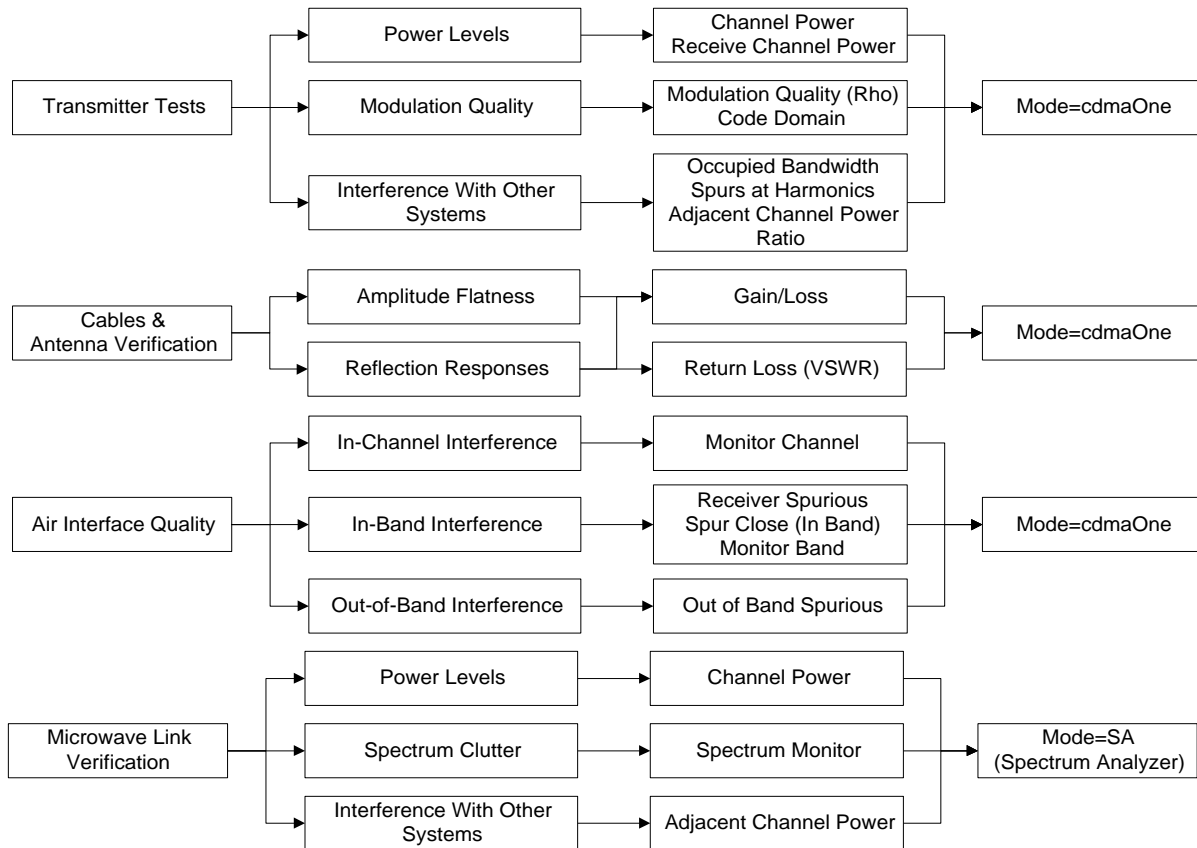

The Fault Finding Process

Four key elements, shown in Figure 1-3, can contribute to degraded cell performance. First, the transmitter is often described as the hardest working component of the cell site. Linear power amplifiers generate high power radio signals and run at high temperatures. Insufficient heat dissipation in humid climates can cause the transmitters to overheat, or extremes of cold can cause transmitter heat sinks to crack. As a result, specified performance will be degraded, causing low power transmissions, impaired modulation, and poor adjacent channel performance.

Next, the cables and antenna are directly exposed to the elements. Weather-damaged antennas, cables, and the connectors can further degrade performance. Sometimes a low noise amplifier close to the antenna is used to boost the signal or microwave radio transceivers are used to link the cell site to the communications network. These components are just as exposed to the same harsh environmental conditions making them prone to failure.

When a mobile site transmits, other radio systems can interfere with the propagated signal resulting in a degraded signal at the cell site receiver. On the journey, interference from other radio systems can degrade the signal. Tall buildings and hills can deflect the signal away from the antenna and signal degradation can result.

Figure 1-3

System Degradation Sources

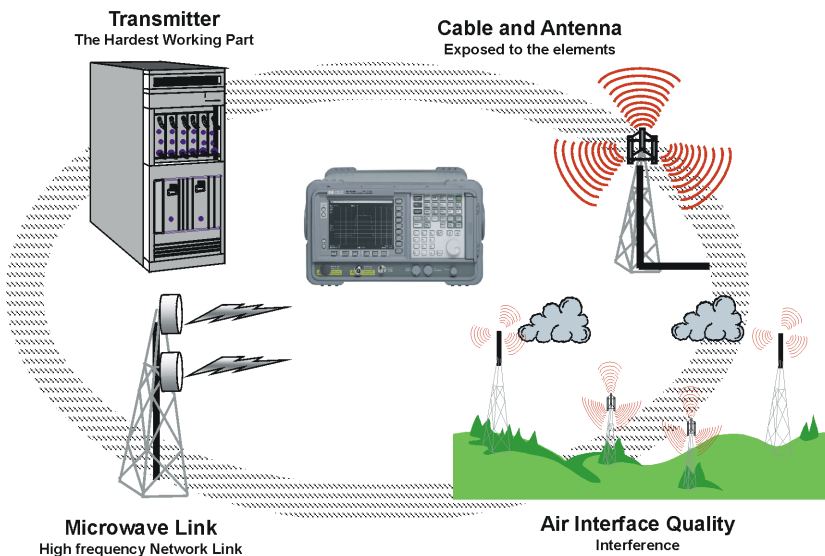

bl716b

To help identify which component of the cell site is contributing to performance problems, a fault finding process is needed. Essentially, once the radio signal is modulated and transmitted, it is prone to degradation. The once perfect, error corrected, monitored digital signal, now has all the characteristics of any analog radio signal. What you want to do is ensure its transmission path is clear and presents no barriers that will hinder its performance. Starting at the transmitter, as indicated in [Figure 1-4](#), you need to check that the correct signal is being generated. You then need to ensure that it passes through the various cables and connectors without degrading its quality. Once transmitted through the antenna, a clear interference free radio band is required to ensure the handset receives the signal correctly. Then in reverse, you need to verify the reception band is clear and the path from the antenna to the receiver presents no obstacles to the radio receiver equipment, which will decode the signal and convert it back into digital data.

When troubleshooting, you need to ask ourselves a set of basic questions. The first thing to question is the transmitter operation where the signal originates. If this is operating satisfactorily, then you need to determine that intermediate components are not attenuating the signal. Finally, you need to ensure that maximum power is being transferred into the antenna feed and array. On the receive side, you again need to ensure that maximum power is being transferred from the antenna to the BTS. You also need to ensure that intermediate components do not over-attenuate the received signal.

Figure 1-4

Fault Finding Process

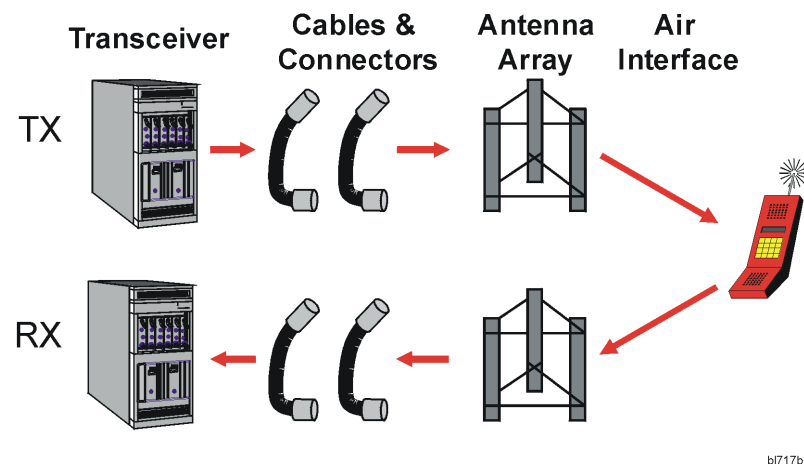

The flow chart in [Figure 1-2](#) provides the basic system diagnostic process for performing various test measurements to troubleshoot your cell site base transceiver system.

Identifying Interfering Signals

To identify interfering signals, you must first locate them in the cdmaOne frequency band. This is best done by using the Monitor Band measurement. Sensitivity should be optimized to locate and view small interfering signals. To optimize the spectrum analyzer for best sensitivity when identifying interference signals, three main parameters need to be understood: resolution bandwidth, internal attenuation, and internal pre-amplification.

First, choose the lowest possible resolution bandwidth filter. The noise floor decreases as resolution bandwidth decreases. This is because noise is a broadband signal, and as you reduce resolution bandwidth, less noise reaches the detector. Sweep speed is inversely proportional to the square of the resolution bandwidth and increases as resolution bandwidth decreases. To optimize speed, the smallest span and largest bandwidth possible should be used that still separate the signals and allow visibility of all signals of interest. Using monitor channel reduces the span by focusing on a specific channel instead of an entire band.

Second, set the internal input attenuator to the least possible amount of attenuation, normally 0 dB. However, if the input signal total power is greater than -10 dBm for 0 dB attenuation, the analyzer may generate internal distortion. To determine if the analyzer is internally generating the distorted signals seen on the display, increase the attenuation and see if the displayed signals change in amplitude. If no amplitude change is evident, the distortion is caused by the unit under test and not the analyzer.

Finally, you can turn on the internal preamplifier (Option 1DS). This will drop the noise floor and allow you to view the signals that were previously below the analyzer noise floor.

Use this procedure and the following examples of interfering signals to help you identify the source of interfering signals and achieve the best sensitivity.

Key Press Procedure			Remarks
Step	Front-Panel Key	Menu Key	
1	Measure	More	The Monitor Band function is used to identify low-level signals that may be interfering in the up- and down-link bands. The sensitivity of this measurement is improved by reducing the resolution bandwidth and removing the analyzer attenuation through Meas Setup .
2		Monitor Band/Channel	
3	Meas Setup	Method <u>Band</u>	
4		Band Setup	
5		Res BW <u>Man</u>	As the resolution bandwidth gets smaller, the sweep time gets longer.
6	↓ (Down Arrow)		
7	Input/Output	RF Input Range <u>Man</u>	
8	AMPLITUDE Y Scale	Attenuation	To achieve 0 dB attenuation, you must enter the value using the numeric key pad. This is a safe guard against inadvertent front-end overload.
9	↓ (Down Arrow)		
10	Peak Search		The marker is used to determine the frequency of the suspected interference signal.
11	FREQUENCY Channel	Channel Freq and enter the marker frequency.	
12	Meas Setup	Method <u>Channel</u>	The spectrum shape of the suspect signal can now be seen.
13		Chan Setup	For very low level signals, use the built-in preamplifier to amplify the input so that the signals appear above the noise floor of the spectrum analyzer.
14		Int Preamp <u>On</u>	

CAUTION

Use a simple attenuator test to determine whether displayed distortion components are true input signals or internally generated signals caused by mixer overload. Press **AMPLITUDE**, **Attenuation**, and ↑ to increase the attenuation. If the amplitude of the suspected signal changes, then it is internally generated. Continue increasing the attenuation until the displayed distortion does not change, then complete the measurement.

Examples of Interference Signals

Use these signal examples to help you assess the bandwidth and spectral shape of the interfering signal in order to determine the type of transmission causing the interference. Use the settings in the following examples to identify the various signals.

Using Monitor Band/Channel to Look for Interfering Signals

Using the Monitor Band and Channel feature can help you quickly identify interfering signals within your transmission and reception bands or channels. Simple visual inspection, peak hold, and markers can help you determine the type of interference that may be causing network problems.

Commercial AM/FM Broadcast Signal:

Press **MEASURE**, **More**, **Monitor Band/Channel**, **Meas Setup**, **Method Channel**

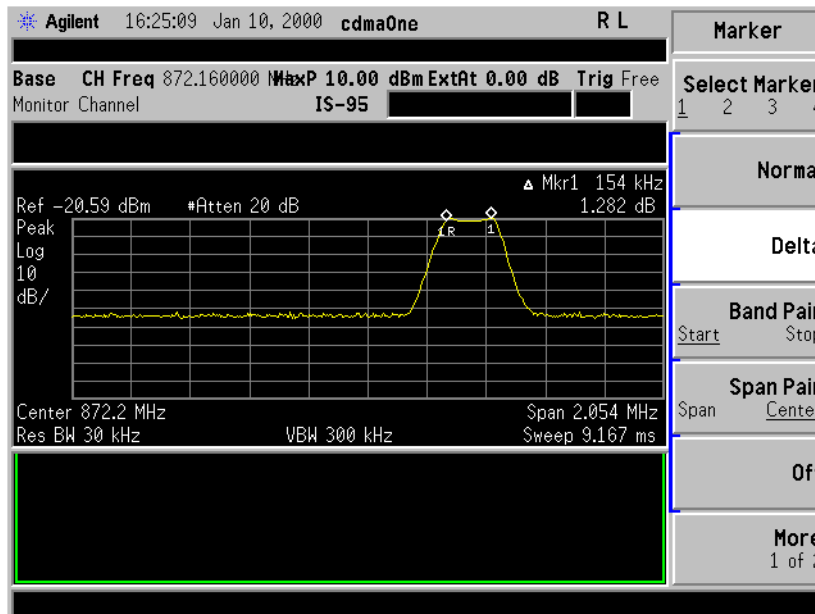

A narrow bandwidth signal within a channel could be caused by AM/FM channels. In SA mode use the built-in AM or optional FM (Option BAA) demod to determine the source of the transmission.

Commercial TV Broadcast Signal:

Press **MEASURE**, **More**, **Monitor Band/Channel**, **Meas Setup**, **Method Band**

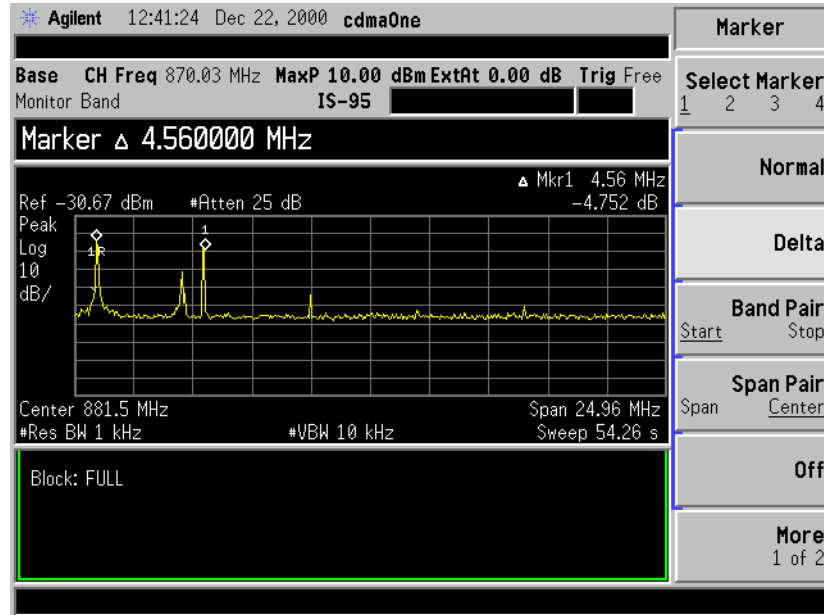

An interfering TV signal can be quickly visually verified by its unique spectral characteristics (two large carriers 4 to 6 MHz apart). In SA mode, use TV Trigger and Picture on Screen, and FM Demodulation (Options BAA and B7B) to determine the transmission source.

cdmaOne Use Model
Identifying Interfering Signals

CDMA Signals:

Press **MEASURE**, **More**, **Monitor Band/Channel**, **Meas Setup**, **Method Band**

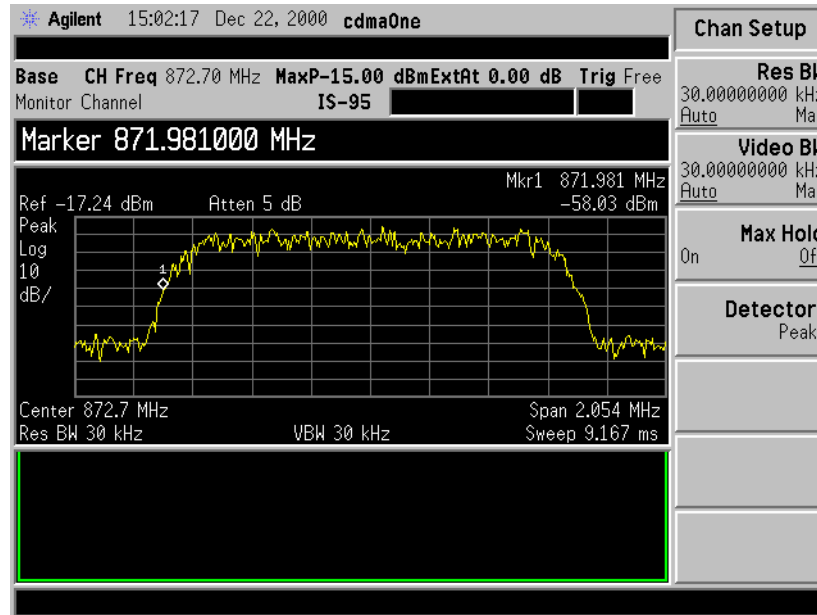

Adjacent interfering CDMA signals will have this type of spectral characteristic.

GSM/PCS Signal:

Press **MEASURE**, **More**, **Monitor Band/Channel**, **Meas Setup**, **Method Band**, **Chan Setup**, **Max Hold On**

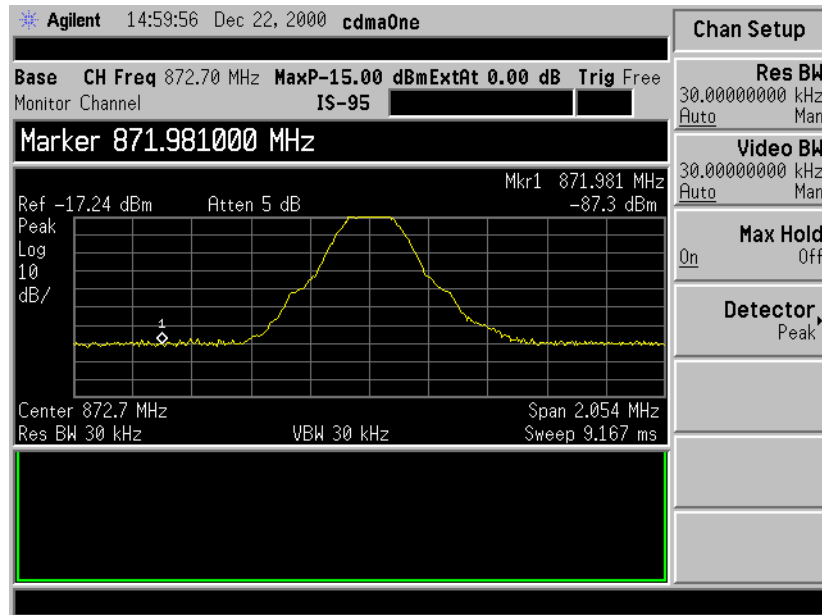

GSM/PCS networks can cause in-band interference. A GSM signal will have this type of spectral characteristic.

Using Demodulation to Look for Interfering Signals

The Modulation Accuracy and Code Domain Power measurement help you determine if an interfering signal is present within your CDMA signal transmission bandwidth.

Modulation Accuracy (Rho) Measurement:

Press **MEASURE**, **Mod Accuracy (Rho)**, **Display**, **Chip Dots 1**

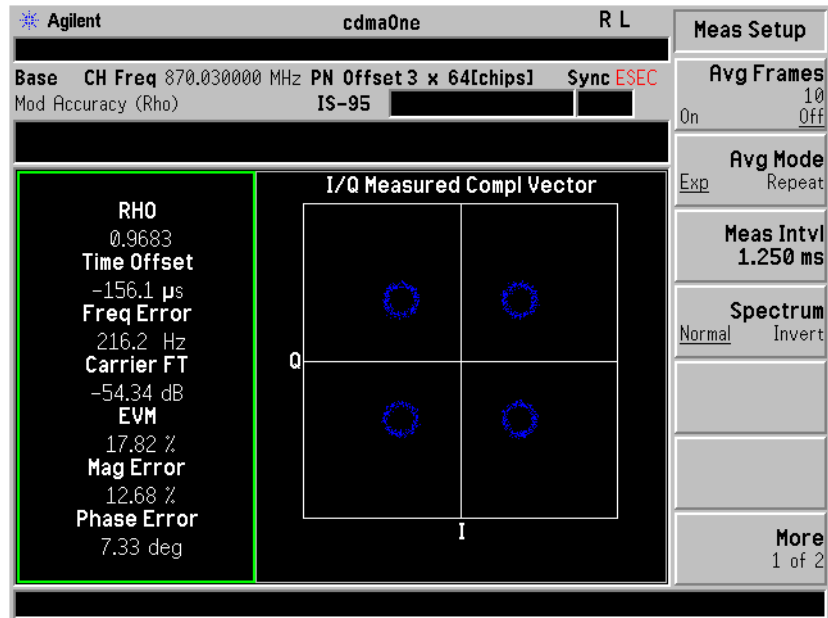

Circles in the constellation indicate an interfering signal. A normal cdmaOne modulated signal will not have openings in the circles. This also indicates a poor signal to noise ratio.

Code Domain Measurement:
 Press **MEASURE**, Code Domain

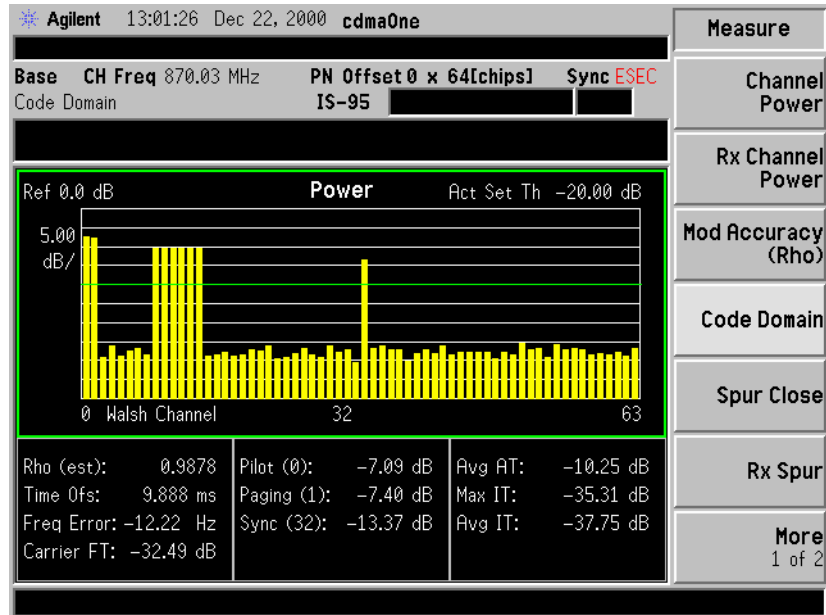

High power in the inactive traffic channels (Avg IT) can indicate there is an interfering signal present. Also, poor linear amplifier performance can cause this type of effect.

Adjacent Channel Power Ratio Measurement:

Press MEASURE, ACPR

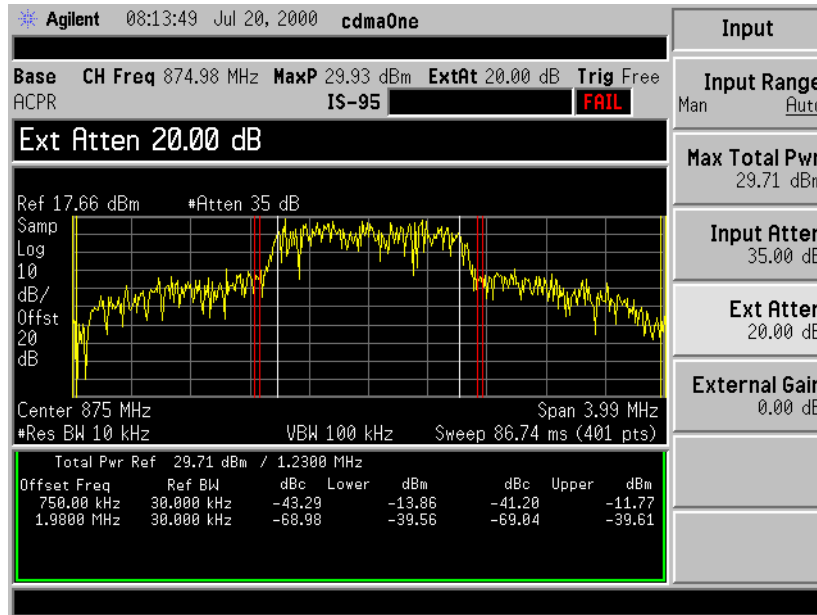

A cdmaOne signal with spectral regrowth in the adjacent channels that exceed the pass/fail limits. Poor linear amplifier performance can cause this type of effect.

cdmaOne Measurements

Once in the cdmaOne mode, the following measurements are available by pressing the **MEASURE** front panel key:

- Channel Power on [page 3-7](#)
- Receive Channel Power on [page 3-12](#)
- Monitor Band/Channel on [page 3-19](#)
- Occupied Bandwidth on [page 3-24](#)
- Adjacent Channel Power Ratio on [page 3-29](#)
- Code Domain on [page 4-3](#)
- Modulation Accuracy (Rho) on [page 4-8](#)
- Spur Close on [page 4-13](#)
- Out of Band Spurious on [page 4-18](#)
- Receiver Spurious on [page 4-23](#)
- Spurs at Harmonics on [page 4-29](#)

These are referred to as one-button measurements. When you press the key to select the measurement it will become the active measurement, using settings and a display unique to that measurement. Data acquisitions will automatically begin if necessary trigger requirements are met.

In addition, the following cdmaOne mode measurements are made using the **Monitor** measurement by pressing the **MEASURE** front panel key:

- Return Loss on [page 3-35](#)
- Loss/Gain on [page 3-39](#)

In addition, the following spectrum analyzer mode measurements are available by pressing the **Mode**, **SA**, and **MEASURE** front panel keys:

- Microwave Transmitter Power on [page 4-33](#)
- Microwave Spectrum Monitoring on [page 4-36](#)
- Microwave Adjacent Channel Power Ratio (ACPR) on [page 4-39](#)

Basic Key Use

The **Mode** key allows you choose basic Spectrum Analyzer or cdmaOne functionality. Next, set global measurement defaults in the analyzer based on your system using **Mode Setup**, for example, IS-95A or J-STD008. When you select a standard, the analyzer will set measurement parameters to meet the standard requirements.

The **Channel Frequency** or **RF Channel** keys allow you tune the analyzer to specific frequencies. You can do this by either setting absolute frequencies or by setting the channel number when in cdmaOne mode.

You can select a number of previously-configured standards based measurements to help you troubleshoot a system using the **Measure** button. Because all measurement situations are different, **Meas Setup** allows you to quickly change some of the measurement parameters. Finally, if you need to quickly start the measurement again, press **Restart** or use **Restart** under **Meas Control**.

Figure 2-1 Basic Keys

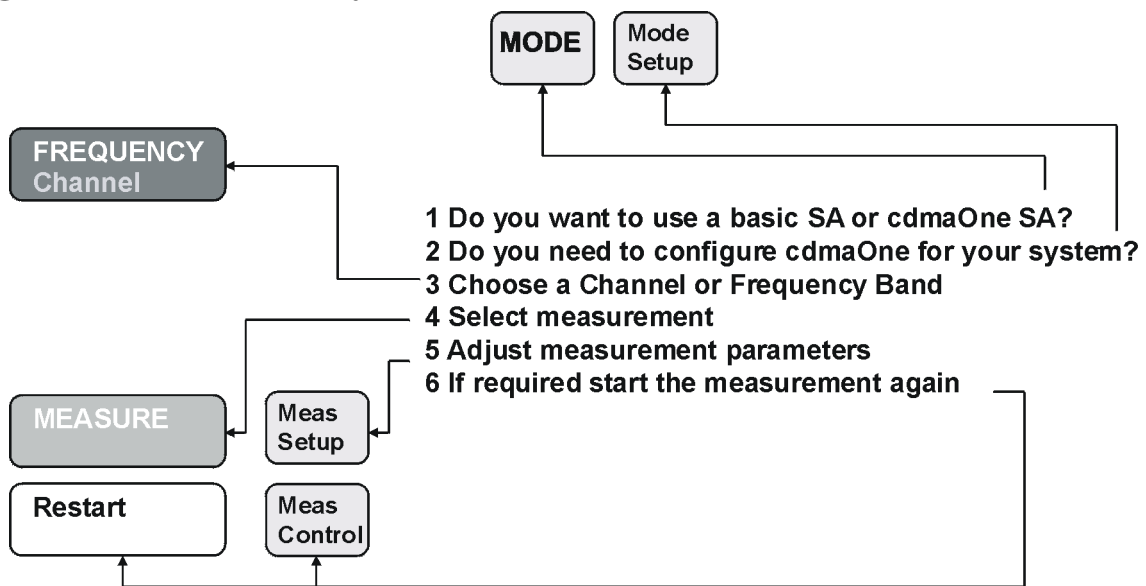

b1715b

Available Basic cdmaOne Measurements

The following basic cdmaOne base transceiver station measurements are described in this chapter:

- ❑ Channel Power on [page 3-7](#)
- ❑ Receive Channel Power on [page 3-12](#)
- ❑ Monitor Band/Channel on [page 3-19](#)
- ❑ Occupied Bandwidth on [page 3-24](#)
- ❑ Adjacent Channel Power Ratio (ACPR) on [page 3-29](#)

In addition, the following spectrum analyzer mode manual measurements are described in this chapter to provide thorough cdmaOne base transceiver station troubleshooting:

- ❑ Return Loss on [page 3-35](#)
- ❑ Loss/Gain on [page 3-39](#)

Making the Channel Power Measurement

Purpose

The Channel Power measurement is useful in determining if poor signal quality is the result of low power levels generated by the transmitter. Modulation accuracy can be reduced by having a lower signal to noise ratio than required. The channel power should be measured first to avoid attributing the effects of a low power level to modulation accuracy errors.

Measurement Method

You can make the Channel Power measurement intrusively or non-intrusively. To perform a non-intrusive test, connect a directional coupler to the RF output with the main arm connected to the antenna and the coupled port connected to the spectrum analyzer as shown in [Figure 3-1](#). Enter the loss due to the effect of the coupler as external attenuation. You may also perform a non-intrusive test by making the measurement at a test port on the transceiver unit, if available.

You can use the intrusive method by taking the measurement directly from the RF output port of the transceiver shown in [Figure 3-2](#). Because you disconnect the antenna from the transceiver and disrupt the transmission signal, this cannot be considered a non-intrusive test.

NOTE Use of a non-intrusive measurement is recommended.

CAUTION If you use the intrusive method, ensure that the power level at the RF input of the spectrum analyzer does not exceed the damage level of 30 dBm.

Measurement Hints

- Use large resolution bandwidth for fast measurements, and a narrow resolution bandwidth for increased sensitivity.
- If the channel power is near the noise floor, set **Noise Correction** to **Auto**. Noise floor correction removes the effects of analyzer noise, improving accuracy when necessary.

NOTE

If **Noise Correction** and **RF Input Range** are both set to **Auto**, the internal input attenuator and reference level will only be set one time and will not automatically update. A change in the input signal level may require an update of the internal input attenuator and reference level. In that case, you will need to press **Restart** to take a new measurement and reset the input attenuator and reference level. This will invalidate the noise floor calibration. You will then be prompted to perform another Noise Floor Calibration or to set **Noise Correction** to **Off** before proceeding with the measurement.

Making the Measurement

1. Ensure that the base transceiver station is in service.
2. Connect the device being measured and the spectrum analyzer input as shown in [Figure 3-1](#) or [Figure 3-2](#).

Figure 3-1 Measurement Setup

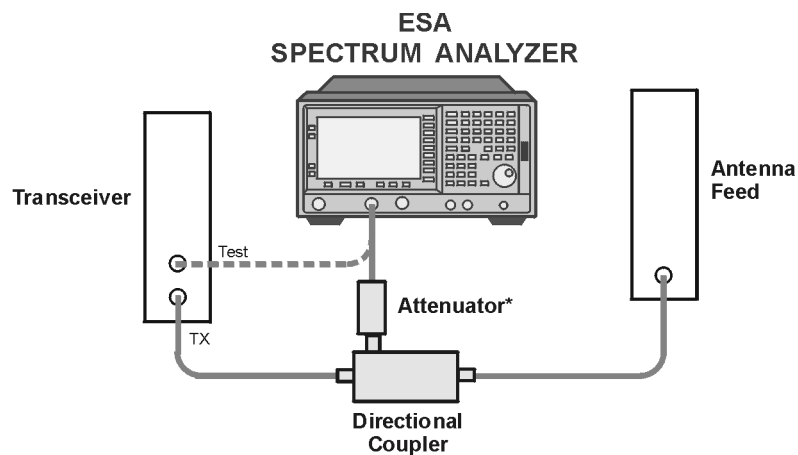

* Use Attenuator to protect the instruments if RF power exceed 30dBm.

b1718b

Figure 3-2 Alternative Measurement Setup

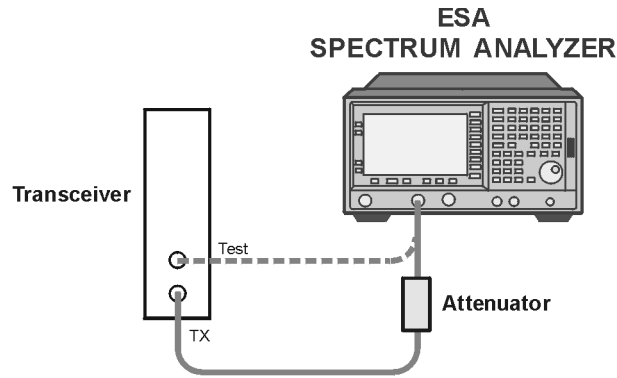

* Use Attenuator to protect the instruments if RF power exceed 30dBm.

b1720b

3. If the mode has not already been set to cdmaOne, press **MODE** and **cdmaOne**.
4. To immediately make Channel Power the active measurement, press **MEASURE** and **Channel Power**.
5. Select the desired center frequency by pressing **FREQUENCY**, then press the appropriate menu key **RF Channel**, **Channel Freq**, or **Temp Ctr Freq**. Enter the desired channel number or frequency value and press **Enter** (for channel numbers) or a units key—**GHz**, **MHz**, **kHz**, or **Hz** (for frequency values).

NOTE

If the desired RF Channel or Channel Freq has been set for a previous measurement, it is used for all subsequent measurements, and it does not need to be set again.

Setting a temporary center frequency does not affect any other measurement, and the measurement reverts to the Channel Frequency on restart.

6. Set the measurement parameters to the default values by pressing **Meas Setup**, **More** and **Restore Meas Defaults**.

NOTE

The factory default settings provide a cdmaOne compliant measurement. For special requirements, you may need to change some of the settings. At any time, you can return all parameters for the current measurement to the default settings by repeating this step.

7. If desired, set the measurement limits to On by pressing **Meas Setup**, **More**, and **Limits**.
8. To change any of the measurement parameters from the factory default values, press the **Meas Setup** key to access menus that allow you to modify the parameters for this measurement. For additional information on keys to access measurement parameters, refer to the *Front-Panel Key Reference* section of the *ESA-E Series Spectrum Analyzers cdmaOne Measurement Personality User's Guide* or use the on-screen help.
9. To save the measurement results, refer to *ESA-E Series Spectrum Analyzers cdmaOne Measurement Personality User's Guide*.

Results

The channel power display shows numerical values for the channel power and power spectral density below the trace display of the cdmaOne signal frequency spectrum. Verify that the channel power is correct for the cell site. If it is incorrect, proceed to the transmitter troubleshooting and adjustments procedures.

Figure 3-3

Channel Power Measurement Results—Standard View

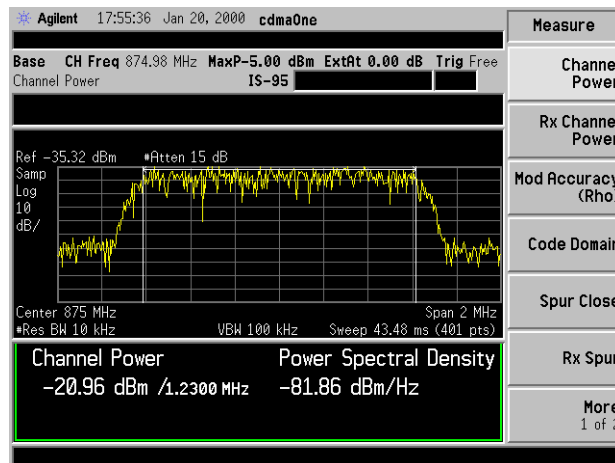
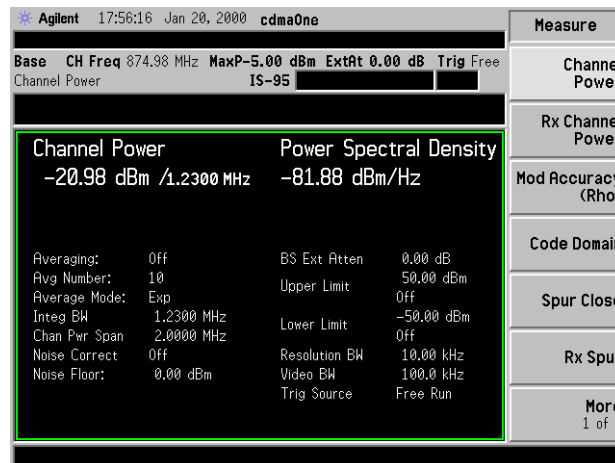

Figure 3-4 Channel Power Measurement Results—Numeric +Parameters View



Troubleshooting Hints

- If the cdmaOne spectrum has spurious signals present in the channel or the modulated signal is oddly shaped, it could be caused by a base band problem. If this is observed, proceed to modulation accuracy measurements (Code Domain Power and Modulation Accuracy (Rho)).
- Low channel power level can be caused by loose or damaged connectors or cables. Loss of power can also be caused by a defective power amplifier or support circuitry. In extreme cases, no power may be measured at the output of the transmitter. Likely causes of this failure could be the cell site transceiver power supply.
- Check for “shoulders” or high points on either side of the spectrum which indicate spectral regrowth. Spectral regrowth can be caused by phase noise, system non-linearity, or power amplifier problems.
- Rounding or sloping of the top of the spectrum can indicate filter shape problems.
- If an external attenuator or directional coupler is used, be sure to include the attenuation value in the measurement. This can be done by entering the **BS Ext Atten** under the **Input/Output** front panel key or the **Input...** key on the **Mode Setup** menu.

Making the Receive Channel Power Measurement

Purpose

Both the transmit and receive band affect system performance. This measurement checks for interference in the receive band by measuring the power level at the input of the transceiver in the receiver band. This verifies both that the transmitter is operating correctly and that the receiver is free from interference by checking for transmitter leakage and the presence of external signals that cause interference present in the receive band.

Measurement Method

This measurement first checks for carrier signals in or around the channel being tested to ensure it is safe to set the attenuation to 0 dB. Then the power in the receive channel is measured in the bandwidth specified by the selected standard and tuning plan.

To improve repeatability, you can increase the number of averages.

You can make the Receive Channel Power measurement intrusively or non-intrusively. To perform a non-intrusive test, connect a directional coupler to the RF output with the main arm connected to the antenna and the coupled port connected to the spectrum analyzer as shown in [Figure 3-5](#). Enter the loss due to the effect of the coupler as external attenuation. You may also perform a non-intrusive test by making the measurement at a test port on the transceiver unit, if available.

You can use the intrusive method by taking the measurement directly from the RF output port of the transceiver as shown in [Figure 3-6](#). Because you disconnect the antenna from the transceiver and disrupt the transmission signal, this cannot be considered a non-intrusive test.

NOTE Use of a non-intrusive measurement is recommended.

CAUTION If you use the intrusive method, ensure that the power level at the RF input of the spectrum analyzer does not exceed the damage level of 30 dBm.

Measurement Hints

- This measurement starts by checking the receive band for a carrier. If a carrier is present, the measurement will continue checking until the carrier is removed. The message, “Measurement is suspended until carrier removed.” will be displayed. If you want to make this measurement with the transmitter on, a band pass filter can be used to eliminate the carrier signal.
- Follow the on-screen directions to optimize for best sensitivity.
- If the channel power is near the noise floor, set **Noise Correction** to **Auto**. Noise floor correction removes the effects of analyzer noise, improving accuracy when necessary.

NOTE

If **Noise Correction** *and* **RF Input Range** are both set to **Auto**, the internal input attenuator and reference level will only be set one time and not automatically update. A change in the input signal level may require an update of the internal input attenuator and reference level. In that case, you will need to press **Restart** to take a new measurement and reset the input attenuator and reference level. This will invalidate the noise floor calibration. You will then be prompted to perform another Noise Floor Calibration or to set **Noise Correction** to **Off** before proceeding with the measurement.

Making the Measurement

1. Ensure that the base transceiver station is in service.
2. Connect the device being measured and the spectrum analyzer input as shown in [Figure 3-5](#) or [Figure 3-6](#).

Figure 3-5 Measurement Setup

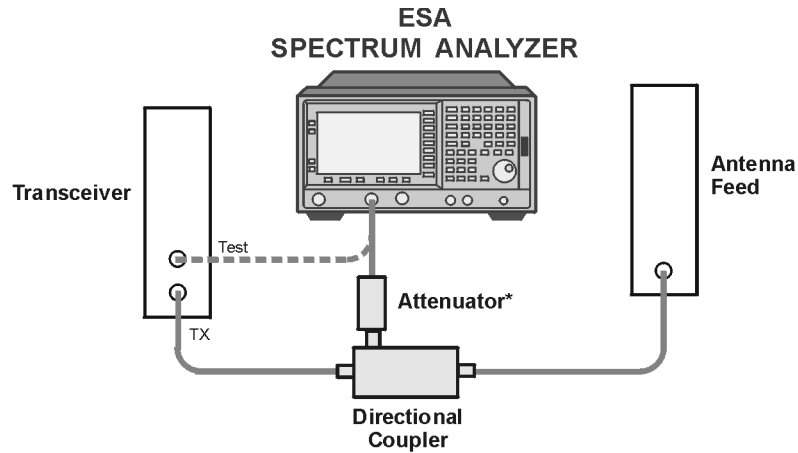

* Use Attenuator to protect the instruments if RF power exceed 30dBm.

bl718b

Figure 3-6 Alternative Measurement Setup

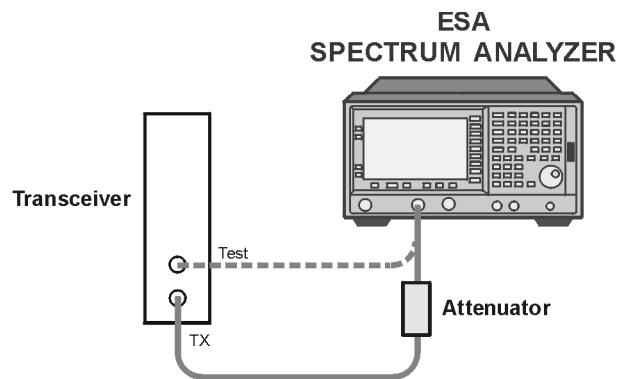

* Use Attenuator to protect the instruments if RF power exceed 30dBm.

bl720b

3. If the mode has not already been set to cdmaOne, press **MODE** and **cdmaOne**.
4. To immediately make Receive Channel Power the active measurement, press **MEASURE** and **Rx Channel Power**. The Preamp dialog box shown in [Figure 3-7](#) will be displayed.

Figure 3-7 Preamp Dialog Box

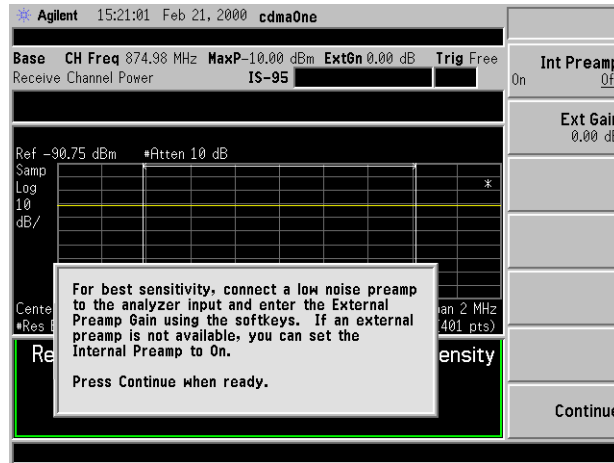

NOTE

If there is no internal preamplifier Option 1DS installed the message will read as follows: “For best sensitivity, connect a low noise preamp to the analyzer input. Set the External Preamp Gain using the softkeys. Press Continue when ready.”

- To continue, follow the instructions in the dialog box and then press **Continue**. The attenuation caution dialog box shown in [Figure 3-8](#) will be displayed.

Figure 3-8 Attenuator Dialog Box

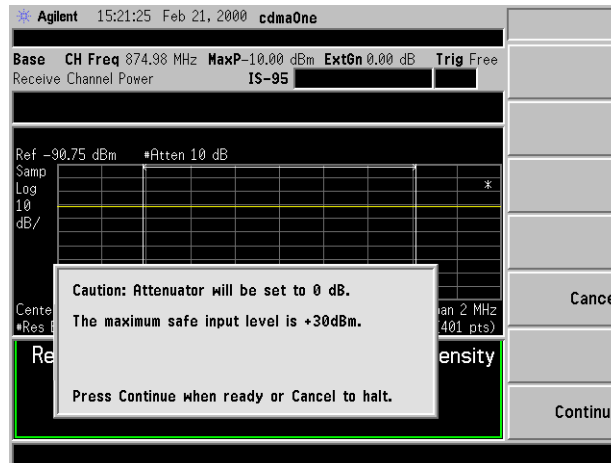

- Set the input signal level according to the instructions in the dialog box. Then, press **Continue** to continue with the measurement or press **Cancel** to terminate the measurement without setting the attenuator to 0 dB.
- Set the measurement parameters to the default values by pressing **Meas Setup, More** and **Restore Meas Defaults**.

NOTE

The factory default settings provide a cdmaOne compliant measurement. For special requirements, you may need to change some of the settings. At any time, you can return all parameters for the current measurement to the default settings by repeating this step.

-
8. If desired, set the measurement limits to On by pressing **Meas Setup**, **More**, and **Limits**.
 9. Select the desired center frequency by pressing **FREQUENCY**, then press the appropriate menu key **RF Channel** or **Temp Ctr Freq**. Enter the desired channel number or frequency value and press **Enter** (for channel numbers) or a units key—**GHz**, **MHz**, **kHz**, or **Hz** (for frequency values).

NOTE

If the desired RF Channel or Channel Freq has been set for a previous measurement, it is used for all subsequent measurements, and it does not need to be set again. The measurement automatically shifts the frequency to the receive frequency for the selected channel. The receive channel frequency is displayed on the **Temp Ctr Freq** menu key.

Setting a temporary center frequency does not affect any other measurement, and the measurement reverts to the Duplex (receive) Channel Frequency, based on the transmit channel frequency, on restart.

-
10. To change any of the measurement parameters from the factory default values, press the **Meas Setup** key to access menus that allow you to modify the parameters for this measurement. For additional information on keys to access measurement parameters, refer to the *Front-Panel Key Reference* section of the *ESA-E Series Spectrum Analyzers cdmaOne Measurement Personality User's Guide* or use the on screen help.
 11. To save the measurement results, refer to *ESA-E Series Spectrum Analyzers cdmaOne Measurement Personality User's Guide*.

Results

The total channel power will be reported along with the power spectral density. This measurement is similar to the channel power measurement, but in the receive band. Base station manufacturers often specify the performance of the receive channel. Compare the measured results with the specification.

Figure 3-9 shows the standard view of receive channel power measurement with a signal at the lower edge of the receive bandwidth.

Figure 3-10 shows the numeric plus parameters view of the same measurement results. The receive channel power, power spectral density, and various measurement parameters are shown.

Figure 3-9

Receive Channel Power Measurement Results—Standard View

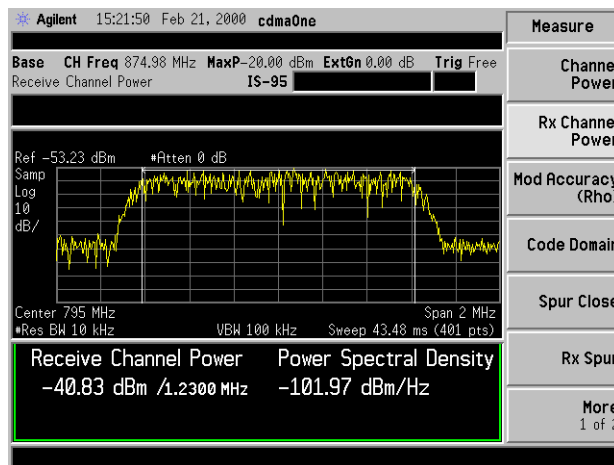
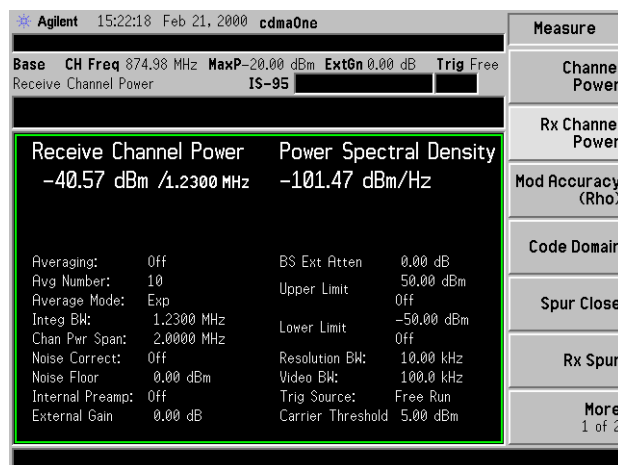

Figure 3-10

Receive Channel Power Measurement Results—Numeric +Parameters View



Troubleshooting Hint

If an external preamplifier is used, be sure to include the gain value in the measurement. This can be done by entering the **External Gain** under the **Input/Output** front panel key or the **Input...** key on the **Mode Setup** menu.

Making the Monitor Band/Channel Measurement

Purpose

You can use the Monitor Band/Channel Measurement to gain a rough idea of system performance and to uncover areas of potential problems. This measurement is especially helpful in verifying that the cdmaOne channel or band is free of interference. By sweeping the specified channel or band of interest, you can identify low level interfering signals. The selected standard and tuning plan determine the band and channel span used for the measurement.

Measurement Method

The channel measurement is a close up of a specific part of a band. In order to focus on a specific part of the band, Press **Meas Setup** and, under the **Method** softkey, press **Channel**.

You can make the Monitor Band/Channel measurement intrusively or non-intrusively. To perform a non-intrusive test, connect a directional coupler to the RF output with the main arm connected to the antenna and the coupled port connected to the spectrum analyzer as shown in [Figure 3-11](#). Enter the loss due to the effect of the coupler as external attenuation. You may also perform a non-intrusive test by making the measurement at a test port on the transceiver unit, if available.

You can use the intrusive method by taking the measurement directly from the RF output port of the transceiver as shown in [Figure 3-12](#). Because you disconnect the antenna from the transceiver and disrupt the transmission signal, this cannot be considered a non-intrusive test.

NOTE

Use of a non-intrusive measurement is recommended.

CAUTION

If you use the intrusive method, ensure that the power level at the RF input of the spectrum analyzer does not exceed the damage level of 30 dBm.

Measurement Hints

- By using the marker and a wide resolution bandwidth (3 MHz) a quick power level check can be made on the channel of interest.
- Using the frequency readout of the marker will also give you an idea of the carrier frequency. This carrier frequency can be entered into the analyzer and converted into a channel number using the **FREQUENCY Channel** key.
- Optimize the analyzer sensitivity by reducing attenuation and turning on the built-in preamplifier (option 1DS). This will reduce the noise floor of the analyzer to uncover any hidden low level signals.
- To improve the resolution of interference signals, refer to [“Identifying Interfering Signals” on page 1-6.](#)

Making the Measurement

1. Ensure that the base transceiver station is out of service.
2. Connect the device being measured and the spectrum analyzer input as shown in [Figure 3-11](#) or [Figure 3-12](#).

Figure 3-11 **Measurement Setup**

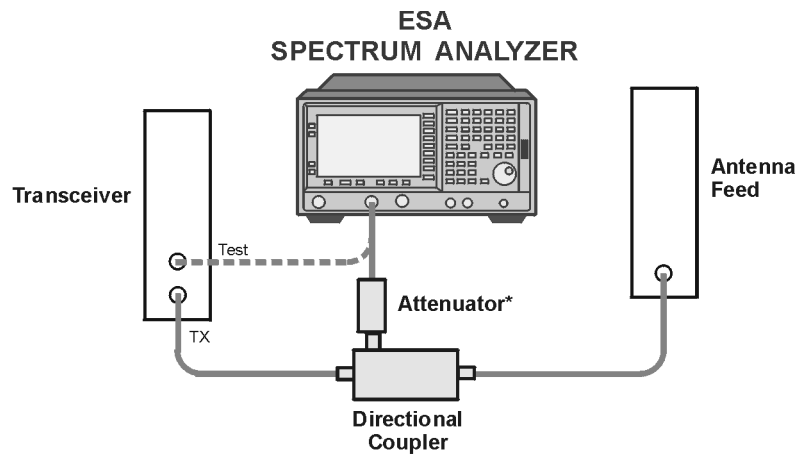

* Use Attenuator to protect the instruments if RF power exceed 30dBm.

bl718b

Figure 3-12 Alternative Measurement Setup

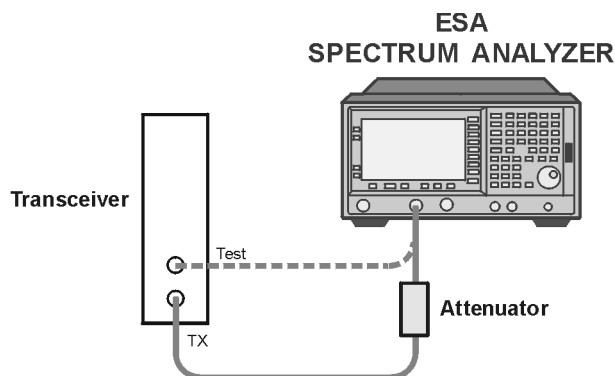

* Use Attenuator to protect the instruments if RF power exceed 30dBm.

b1720b

3. If the mode has not already been set to cdmaOne, press **MODE** and **cdmaOne**.
4. To immediately make Monitor Channel/Band the active measurement, press **MEASURE** and **Monitor Band/Channel**.
5. Select the desired center frequency by pressing **FREQUENCY**, then press the appropriate menu key **RF Channel**, **Channel Freq**, or **Temp Ctr Freq**. Enter the desired channel number or frequency value and press **Enter** (for channel numbers) or a units key—**GHz**, **MHz**, **kHz**, or **Hz** (for frequency values).

NOTE

If the desired RF Channel or Channel Freq has been set for a previous measurement, it is used for all subsequent measurements, and it does not need to be set again.

Setting a temporary center frequency does not affect any other measurement and the measurement reverts to the Channel Frequency on restart.

6. Set the measurement parameters to the default values by pressing **Meas Setup** and **Restore Meas Defaults**.

NOTE

The factory default settings provide a cdmaOne compliant measurement. For special requirements, you may need to change some of the settings. At any time, you can return all parameters for the current measurement to the default settings by repeating this step.

7. Set the measurement method to Channel or Band by pressing **Meas Setup** and **Method** until the desired measurement method is underlined.

- To change any of the measurement parameters from the factory default values, press the **Meas Setup** key to access menus that allow you to modify the parameters for this measurement. For additional information on keys to access measurement parameters, refer to the *Front-Panel Key Reference* section of the *ESA-E Series Spectrum Analyzers cdmaOne Measurement Personality User's Guide* or use the on screen help.
- To save the measurement results, refer to *ESA Spectrum Analyzers User's Guide*.

Results

This measurement provides a quick check to the health of the system. If no problems were detected, continue on with more detailed testing. The following figures provide examples of the measurement results displaying various signals found in the cdmaOne Band or Channel. [Figure 3-13](#) shows the band method measurement with a strong cdmaOne modulated signal; this could include the signal from your system. [Figure 3-14](#) shows the channel method measurement with the same strong modulated signal seen in [Figure 3-13](#); that signal RF frequency has been used as the measurement center frequency.

Figure 3-13

Band Method with CDMA Modulated Signal

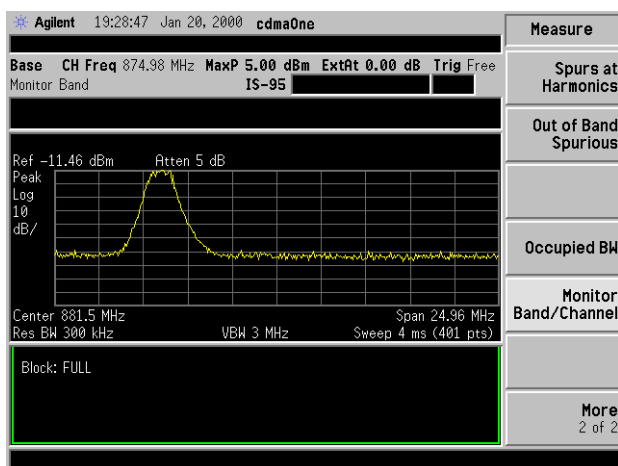
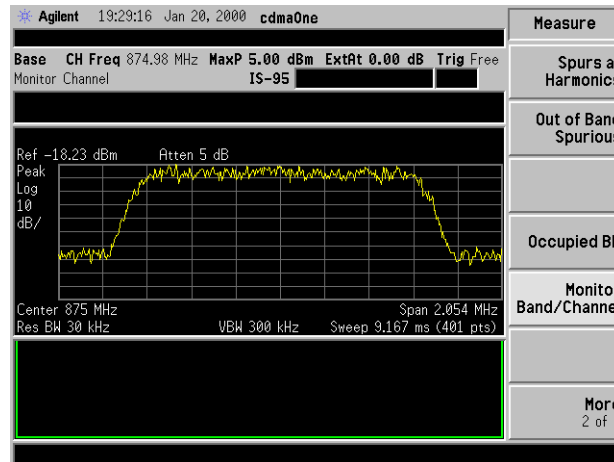

Figure 3-14 Channel Method with CDMA Modulated Signal



Troubleshooting Hints

- To improve the noise floor performance of the analyzer, use **Res BW** under **Meas Setup** to decrease the resolution bandwidth, or use **Attenuation** under **AMPLITUDE Y Scale** to increase the attenuation.
- If a large number of signals are present, the ESA may be generating them internally. To determine if the signals are internally generated, use **Attenuation** under **AMPLITUDE Y Scale** to increase the attenuation. If the spurious signals change in amplitude or decreases in number, then the analyzer is generating distortion.
- If interfering signals are found, they must be eliminated to ensure a properly working network. This should be done first before moving on to other tests.
- If the power level was suspect when measured by this method, use the channel power measurement to get a more accurate power value.
- If an external attenuator is used, be sure to include the attenuation value in the measurement. This can be done by entering the **BS Ext Atten** under the **Input/Output** front panel key or the **Input...** key on the **Mode Setup** menu.

Making the Occupied Bandwidth Measurement

Purpose

Transmission bandwidth is often tightly regulated. Bandwidth occupied by a specified percentage of the total transmit power is determined by this measurement. Distortion in the transmitted signal will produce power outside of the specified bandwidth. Emission bandwidth is also reported to further help identify problems with the transmission.

Measurement Method

This procedure measures the total linear power in the specified measurement span. The power is then used to calculate the upper and lower frequencies of the occupied bandwidth.

You can make the Occupied Bandwidth measurement intrusively or non-intrusively. To perform a non-intrusive test, connect a directional coupler to the RF output with the main arm connected to the antenna and the coupled port connected to the spectrum analyzer as shown in [Figure 3-15](#). Enter the loss due to the effect of the coupler as external attenuation. You may also perform a non-intrusive test by making the measurement at a test port on the transceiver unit, if available.

You can use the intrusive method by taking the measurement directly from the RF output port of the transceiver as shown in [Figure 3-16](#). Because you disconnect the antenna from the transceiver and disrupt the transmission signal, this cannot be considered a non-intrusive test.

NOTE	Use of a non-intrusive measurement is recommended.
-------------	--

CAUTION	If you use the intrusive method, ensure that the power level at the RF input of the spectrum analyzer does not exceed the damage level of 30 dBm.
----------------	---

Measurement Hints

- The emission bandwidth indicates the total transmit power bandwidth which gives an idea of the severity of the distortion
- The occupied bandwidth power percent can be adjusted for your particular measurement needs.

Making the Measurement

1. Ensure that the base transceiver station is in service.
2. Connect the device being measured and the spectrum analyzer input as shown in [Figure 3-15](#) or [Figure 3-16](#).

Figure 3-15 Measurement Setup

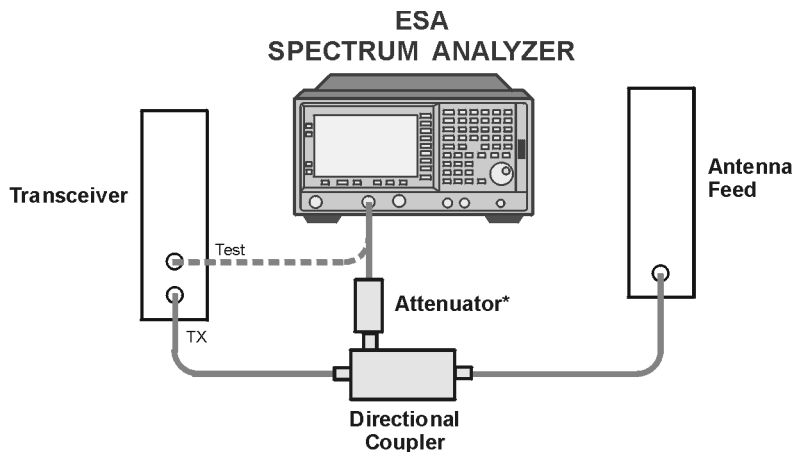

* Use Attenuator to protect the instruments if RF power exceed 30dBm.

b1718b

Figure 3-16 Alternative Measurement Setup

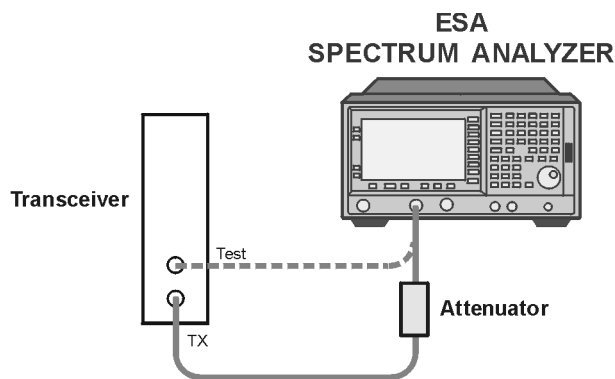

* Use Attenuator to protect the instruments if RF power exceed 30dBm.

b1720b

3. If the mode has not already been set to cdmaOne, press **MODE** and **cdmaOne**.
4. To immediately make Occupied Bandwidth the active measurement, press **MEASURE**, **More**, and **Occupied Bandwidth**.
5. Select the desired center frequency by pressing **FREQUENCY**, then press the appropriate menu key **RF Channel**, **Channel Freq**, or **Temp Ctr Freq**. Enter the desired channel number or frequency value and press **Enter** (for channel numbers) or a units key—**GHz**, **MHz**, **kHz**, or **Hz** (for frequency values).

NOTE

If the desired RF Channel or Channel Freq has been set for a previous measurement, it is used for all subsequent measurements, and it does not need to be set again.

Setting a temporary center frequency does not affect any other measurement, and the measurement reverts to the Channel Frequency on restart.

6. Set the measurement parameters to the default values by pressing **Meas Setup**, **More** and **Restore Meas Defaults**.

NOTE

The factory default settings provide a cdmaOne compliant measurement. For special requirements, you may need to change some of the settings. At any time, you can return all parameters for the current measurement to the default settings by repeating this step.

7. If desired, set the measurement limits to On by pressing **Meas Setup**, **More**, and **Limits**.
8. To change any of the measurement parameters from the factory default values, press the **Meas Setup** key to access menus that allow you to modify the parameters for this measurement. For additional information on keys to access measurement parameters, refer to the *Front-Panel Key Reference* section of the *ESA-E Series Spectrum Analyzers cdmaOne Measurement Personality User's Guide* or use the on screen help.
9. To save the measurement results, refer to *ESA Spectrum Analyzers User's Guide*.

Results

If the occupied bandwidth is larger than anticipated, more analysis of the transmitter is necessary to identify the cause of the distortion. Both the emission bandwidth and transmit frequency error results provide additional information that may indicate the cause of the transmission of power outside of the designed and specified bandwidth.

Figure 3-17 shows the cdmaOne signal with ideal bandwidth power. Figure 3-18 shows the cdmaOne signal with power high points outside of the bandwidth spectrum; this indicates spectral regrowth. A higher span setting has been used to more clearly show the interference in the adjacent channels. Figure 3-19 shows the cdmaOne signal with rounding or sloping of the top of the spectrum; this can indicate filter shaping problems.

Figure 3-17 Standard Results View with a Good cdmaOne Signal

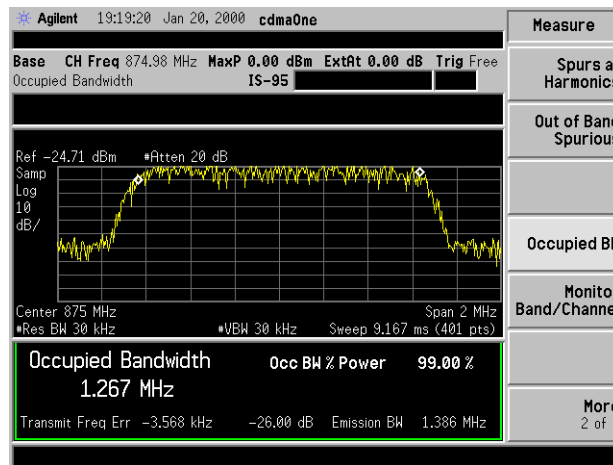

Figure 3-18 Standard Results View with Spectral Regrowth

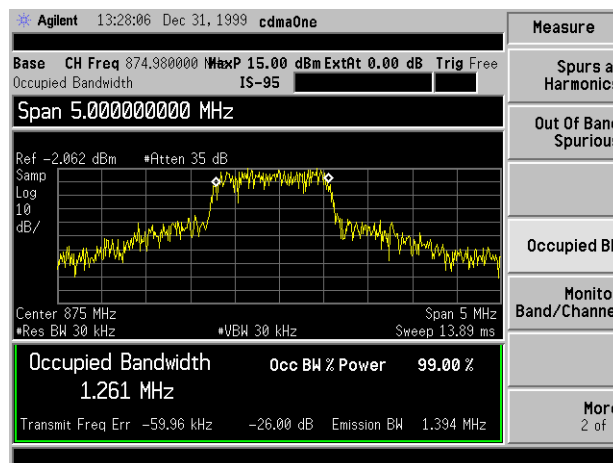

Figure 3-19 Standard Results View with Filter Shaping Problems

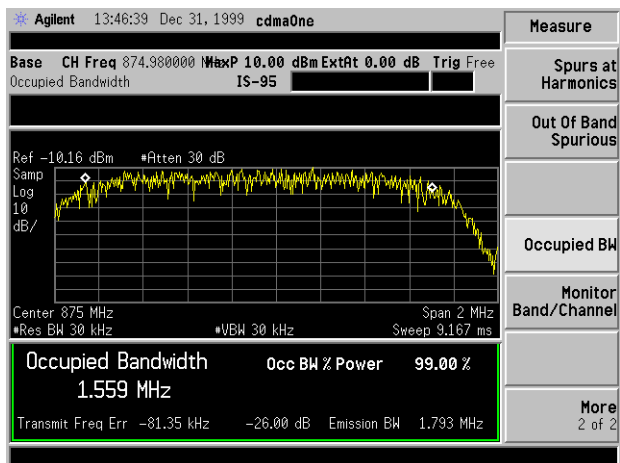

Figure 3-20 Numeric +Parameters View with a Good cdmaOne Signal



Troubleshooting Hints

- If an external attenuator is used, be sure to include the attenuation value in the measurement. This can be done by entering the **BS Ext Atten** under the **Input/Output** front panel key or the **Input...** key on the **Mode Setup** menu.
- Check for “shoulders” or high points on either side of the spectrum which indicate spectral regrowth. Spectral regrowth can be caused by phase noise, system non-linearity, or power amplifier problems.
- Rounding or sloping of the top of the spectrum can indicate filter shape problems.

Making the Adjacent Channel Power Ratio (ACPR) Measurement

Purpose

Adjacent Channel Power Ratio (ACPR) is the power contained in a specified frequency channel bandwidth relative to the total carrier power. It may also be expressed as a ratio of power spectral densities between the carrier and the specified offset frequency. The absolute power at the specified offset is also provided in dBm or dBm/Hz.

ACPR combines both in-band and out-of-band specifications to provide useful figures-of-merit for spectral regrowth and emissions produced by components and circuit blocks without the rigor of performing a full spectrum emissions mask measurement.

Measurement Method

This procedure measures the total RMS power in the main channel and in upper and lower pairs of adjacent bandwidths. The ratio of the power in the adjacent bandwidths to the power in the main channel, in dBc, is the reported result. The absolute power of the main channel and the adjacent bandwidths, in dBm, are also reported. The adjacent bandwidths are specified by their location (offset frequency—the difference between the center of the adjacent channel and the center of the main channel) and their width (adjacent channel bandwidth).

You can make the Adjacent Channel Power Ratio measurement intrusively or non-intrusively. To perform a non-intrusive test, connect a directional coupler to the RF output with the main arm connected to the antenna and the coupled port connected to the spectrum analyzer as shown in [Figure 3-21](#). Enter the loss due to the effect of the coupler as external attenuation. You may also perform a non-intrusive test by making the measurement at a test port on the transceiver unit, if available.

You can use the intrusive method by taking the measurement directly from the RF output port of the transceiver as shown in [Figure 3-22](#). Because you disconnect the antenna from the transceiver and disrupt the transmission signal, this cannot be considered a non-intrusive test.

CAUTION

If you use the intrusive method, ensure that the power level at the RF input of the spectrum analyzer does not exceed the damage level of 30 dBm.

NOTE

Use of a non-intrusive measurement is recommended.

Making the Measurement

1. Ensure that the base transceiver station is in service.
2. Connect the device being measured and the spectrum analyzer input as shown in [Figure 3-21](#) or [Figure 3-22](#).

Figure 3-21 Measurement Setup

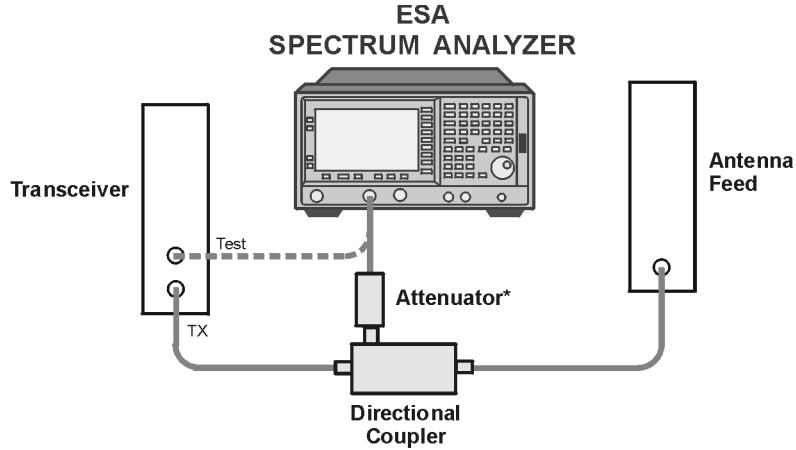

* Use Attenuator to protect the instruments if RF power exceed 30dBm.

bl718b

Figure 3-22 Alternative Measurement Setup

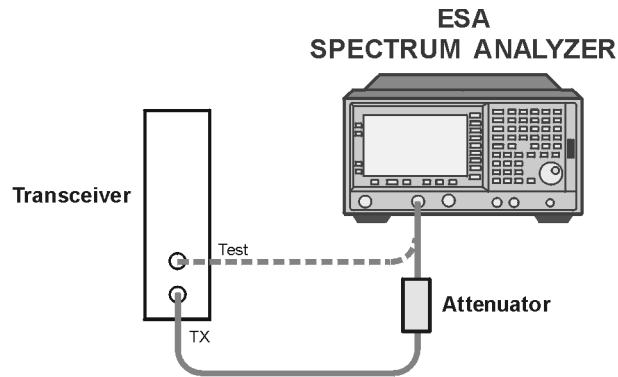

* Use Attenuator to protect the instruments if RF power exceed 30dBm.

bl720b

3. If the mode has not already been set to cdmaOne, press **MODE** and **cdmaOne**.
4. To immediately make Adjacent Channel Power Ratio the active measurement, press **MEASURE** and **ACPR**.

5. Select the desired center frequency by pressing **FREQUENCY**, then press the appropriate menu key **RF Channel**, **Channel Freq**, or **Temp Ctr Freq**. Enter the desired channel number or frequency value and press **Enter** (for channel numbers) or a units key—**GHz**, **MHz**, **kHz**, or **Hz** (for frequency values).

NOTE

If the desired RF Channel or Channel Freq has been set for a previous measurement, it is used for all subsequent measurements, and it does not need to be set again.

Setting a temporary center frequency does not affect any other measurement, and the measurement reverts to the Channel Frequency on restart.

6. Set the measurement parameters to the default values by pressing **Meas Setup**, **More** and **Restore Meas Defaults**.

NOTE

The factory default settings provide a cdmaOne compliant measurement. For special requirements, you may need to change some of the settings. At any time, you can return all parameters for the current measurement to the default settings by repeating this step.

7. If desired, set the measurement offset frequencies and limits to On by pressing **Meas Setup** and **Ofs & Limits**.
8. To change any of the measurement parameters from the factory default values, press the **Meas Setup** key to access menus that allow you to modify the parameters for this measurement. For additional information on keys to access measurement parameters, refer to the *Front-Panel Key Reference* section of the *ESA-E Series Spectrum Analyzers cdmaOne Measurement Personality User's Guide* or use the on-screen help.
9. To save the measurement results, refer to *ESA-E Series Spectrum Analyzers cdmaOne Measurement Personality User's Guide*.

Results

Figure 3-23 shows an example result of ACPR (Total Pwr Ref) measurement in the bar graph window. The absolute power level of the carrier frequency is displayed in the graphic window. The absolute and relative power levels at the selected offset frequencies, on both sides of the carrier frequency, can be determined in the graphic window.

The absolute power level of the carrier frequency is shown in the text window. In addition, the absolute and relative power levels at the selected offset frequencies, on both sides of the carrier frequency, are shown in a table format in the text window.

Figure 3-23

ACPR Measurement - Bar Graph View

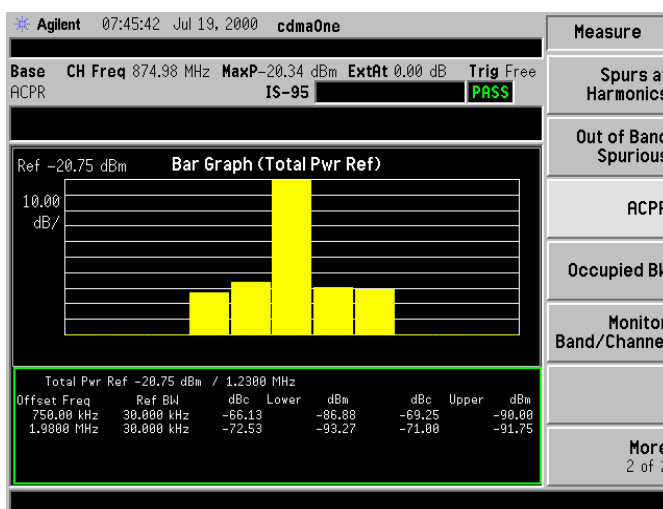

Figure 3-24 shows an example result of ACPR (Total Pwr Ref) measurements in the spectrum window. The absolute power level of the carrier frequency is displayed in the graph window. The absolute and relative power levels at the selected offset frequencies, on both sides of the carrier frequency, can be determined in the graph window. The vertical bars indicate the selected offsets and the associated offset bandwidth. This view makes it possible for you to determine if there is a signal adjacent to the reference signal, and if any of the signal power is in the selected offsets.

The absolute power level of the carrier frequency is shown in the text window. In addition, the absolute and relative power levels at the selected offset frequencies, on both sides of the carrier frequency, are shown in a table format in the text window.

Figure 3-24 ACPR Measurement Results—Spectrum View

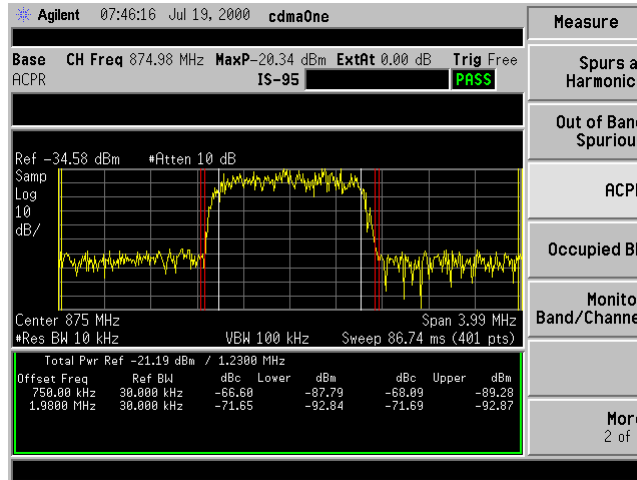
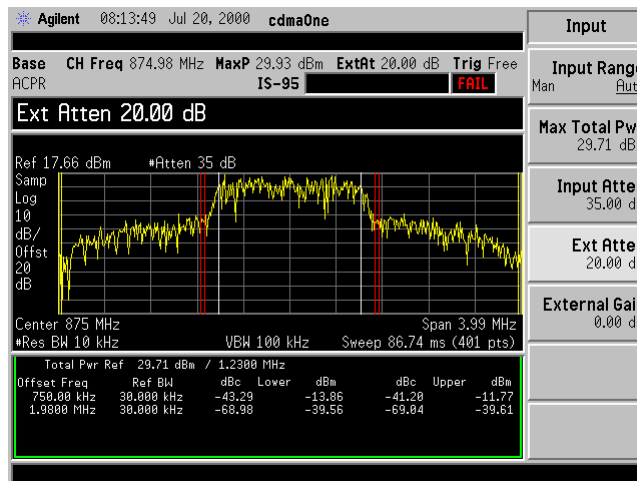

Figure 3-25 shows an example result of ACPR (Total Pwr Ref) measurement with spectral regrowth in the adjacent channels that exceed the pass/fail limits. Poor linear amplifier performance can cause this type of effect.

Figure 3-25 ACPR Measurement Results with Spectral Regrowth



Troubleshooting Hints

If you do not obtain the expected results, repeat the setup procedure to check the integrity of the test connections.

This adjacent channel power ratio measurement can reveal degraded or defective parts in the transmitter section of the UUT. The following examples are areas to be checked further.

- Some faults in the DC power supply control of the transmitter power amplifier, RF power controller of the pre-power amplifier stage, or I/Q control of the baseband stage
- Some degradation in the gain and output power level of the amplifier due to the degraded gain control and/or increased distortion
- Some degradation of the amplifier linearity and other performance characteristics

Power amplifiers are one of the final stage elements of a base or mobile transmitter and are a critical part of meeting the important power and spectral efficiency specifications. Since ACPR measures the spectral response of the amplifier to a complex wideband signal, it is a key measurement linking amplifier linearity and other performance characteristics to the stringent system specifications.

Making Return Loss Measurements

Purpose

Return loss is used to determine the health of an antenna system and its associated cabling by measuring the amount of transmitted power reflected back from the antenna system and not radiated from the antenna to the mobile user.

Cables and antennae are often subjected to harsh weather conditions resulting in a performance which deteriorates over time, leading to an eventual failure. By monitoring return loss over time, cable and antennae performance can be monitored and preventive action taken when required.

Measurement Method

You can only make the Return Loss measurement intrusively. Take the measurement directly from the antenna feed port as shown in [Figure 3-27](#). Because you disconnect the antenna from the transceiver and disrupt the transmission signal, this is an intrusive test.

Making the measurement

Measurement Normalization

1. Connect the tracking generator, signal separation device, short (or open), and the spectrum analyzer input as shown in [Figure 3-26](#).

Figure 3-26 Normalizing the Measurement

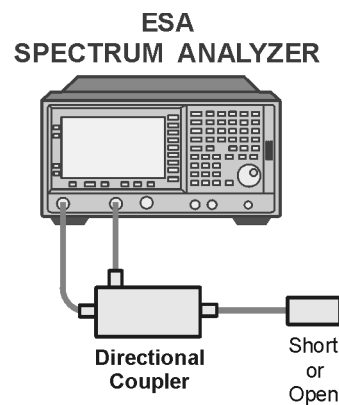

bh81b

2. If the mode has not already been set to cdmaOne, press **MODE** and **cdmaOne**.
3. Press **MEASURE**, **More**, and **Monitor Band/Channel**.

4. Set the measurement method to Band by pressing **Meas Setup** and **Method** until **Band** is underlined.
5. Turn on the RF Tracking Generator by pressing **Source** and then **Amplitude** until **On** is underlined.
 - a. Set an amplitude level appropriate for the device under test. The default value is -10 dBm. For systems with higher loss, you may use 0 dBm.
6. Make all measurements relative by pressing **View/Trace**, **More**, **Normalize**, **Store Ref (1→3)**, and then press **Normalize** until **On** is underlined.

Measurement

1. Ensure that the base transceiver station is in service.
2. Connect the tracking generator, signal separation device, device being measured, and the spectrum analyzer input as shown in [Figure 3-27](#).

Figure 3-27 Measurement Setup

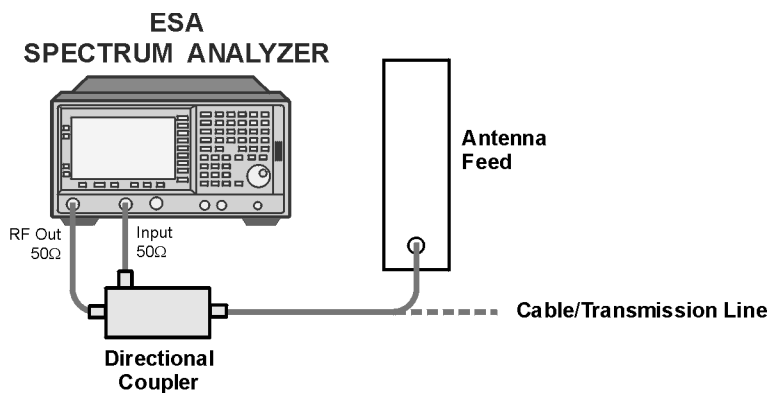

b710b

3. Set the view to Trace 3 by pressing **View/Trace**, **Trace 3**, and **Blank**.
4. Use the marker to locate any reflected signal by pressing **Peak Search**.
5. Convert the peak dBm value into VSWR using [Table 3-1 on page 3-37](#).
6. To save the measurement results, refer to *ESA Spectrum Analyzers User's Guide*.

Converting return loss to VSWR

Return loss can be expressed as a voltage standing wave ratio (VSWR) value using the following table or formula.

Table 3-1 Power to VSWR Conversion

Return Loss (dB)	VSWR	Return Loss (dB)	VSWR	Return Loss (dB)	VSWR	Return Loss (dB)	VSWR	Return Loss (dB)	VSWR
4.0	4.42	14.0	1.50	18.0	1.29	28.0	1.08	38.0	1.03
6.0	3.01	14.2	1.48	18.5	1.27	28.5	1.08	38.5	1.02
8.0	2.32	14.4	1.47	19.0	1.25	29.0	1.07	39.0	1.02
10.0	1.92	14.6	1.46	19.5	1.24	29.5	1.07	39.5	1.02
10.5	1.85	14.8	1.44	20.0	1.22	30.0	1.07	40.0	1.02
11.0	1.78	15.0	1.43	20.5	1.21	30.5	1.06	40.5	1.02
11.2	1.76	15.2	1.42	21.0	1.20	31.0	1.06	41.0	1.02
11.4	1.74	15.4	1.41	21.5	1.18	31.5	1.05	41.5	1.02
11.6	1.71	15.6	1.40	22.0	1.17	32.0	1.05	42.0	1.02
11.8	1.69	15.8	1.39	22.5	1.16	32.5	1.05	42.5	1.02
12.0	1.67	16.0	1.38	23.0	1.15	33.0	1.05	43.0	1.01
12.2	1.65	16.2	1.37	23.5	1.14	33.5	1.04	43.5	1.01
12.4	1.63	16.4	1.36	24.0	1.13	34.0	1.04	44.0	1.01
12.6	1.61	16.6	1.35	24.5	1.13	34.5	1.04	44.5	1.01
12.8	1.59	16.8	1.34	25.0	1.12	35.0	1.04	45.0	1.01
13.0	1.58	17.0	1.33	25.5	1.11	35.5	1.03	45.5	1.01
13.2	1.56	17.2	1.32	26.0	1.11	36.0	1.03	46.0	1.01
13.4	1.54	17.4	1.31	26.5	1.10	36.5	1.03	46.5	1.01
13.6	1.53	17.6	1.30	27.0	1.09	37.0	1.03	47.0	1.01
13.8	1.51	17.8	1.30	27.5	1.09	37.5	1.03	47.5	1.01

$$VSWR = \frac{1 + 10^{\frac{-RL}{20}}}{1 - 10^{\frac{-RL}{20}}}$$

Where: RL is the measured return loss value.

VSWR is the relationship of the magnitude of the reflected signal and the forward signal; it is expressed as a ratio (for example: 1.2:1 VSWR). The first number is the VSWR value taken from the table or calculated using the formula. The second number is always 1."

Results

Some of the energy incident upon a device can be reflected back towards the source. A return loss measurement quantifies this reflected energy. This measurement provides a relative measure of the transmission power that is being reflected back to the transmitter. Save the results as a baseline measurement to compare to measurements taken in the future. If this measurement has been made in the past. Compare this results to the baseline values. Degeneration can be determined on a relative basis.

Figure 3-28 Example Bandpass Filter Return Loss Measurement

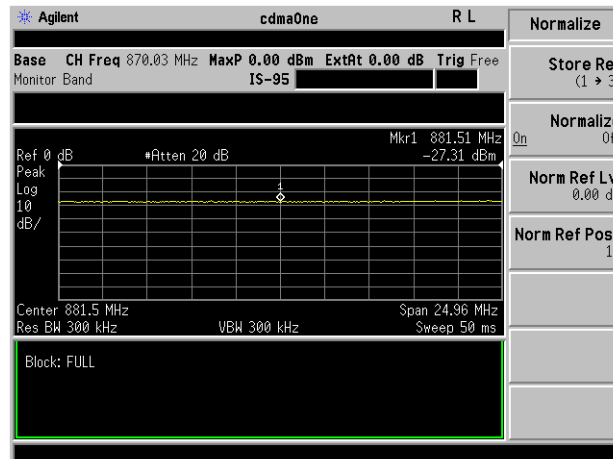

Troubleshooting Hints

If you do not obtain the expected results do the following:

- Repeat the setup procedure to check the integrity of the test connections.
- Check VSWR to verify maximum power transfer.

Making Loss/Gain Measurements

Purpose

Gain/Loss measurements are used to verify the performance of system devices or components. The gain of an active device or losses through a passive device can be monitored and trended to anticipate failure. For example:

- Lower than expected base station power measurements could be caused by faulty cables. The severity of the cable loss can be determined by measuring the loss and comparing the result to the expected value.
- A lower than expected amplifier gain measurement could indicate a fault and incipient failure with the amplifier.

Measurement Method

You can only make the Loss/Gain measurement intrusively. Take the measurement directly from the antenna feed port as shown in [Figure 3-30](#). Because you disconnect the antenna from the transceiver and disrupt the transmission signal, this cannot be considered a non-intrusive test. Enter the loss due to the effect of the coupler as external attenuation.

CAUTION

Ensure that the power level at the RF input of the spectrum analyzer does not exceed the damage level of 30 dBm.

Measurement Hints

- If making a passband-ripple measurement, the spectrum analyzer requires a narrow span and typically < 10 dB per vertical division to get more resolution on the display.
- If making a stop-band attenuation measurement, the spectrum analyzer requires a wide span and a narrow RBW filter.
- Optimize the analyzer sensitivity by reducing attenuation and turning on the preamplifier (option 1DS). This will reduce the noise floor of the analyzer to uncover any hidden low level signals.

Making the measurement

Measurement Normalization

1. Connect the tracking generator to the spectrum analyzer 50 ohm RF input as shown in [Figure 3-29](#).

Figure 3-29 Normalizing the Measurement

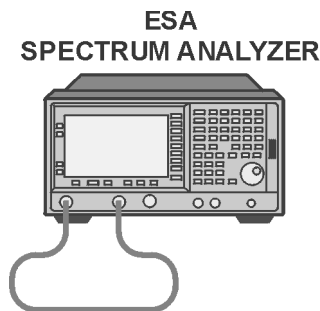

b1722b

2. If the mode has not already been set to cdmaOne, press **MODE** and **cdmaOne**.
3. To immediately make Monitor Channel/Band the active measurement, press **MEASURE** and **Monitor Band/Channel**.
4. Set the measurement parameters to the default values by pressing **Meas Setup**, **More** and **Restore Meas Defaults**.

NOTE

The factory default settings provide a cdmaOne compliant measurement. You will need to change some of the settings for this measurement.

5. Set the measurement method to Band by pressing **Meas Setup** and **Method** until **Band** is underlined.
6. Select the desired center frequency by pressing **FREQUENCY**, then press the appropriate menu key **RF Channel**, **Channel Freq**, or **Temp Ctr Freq**. Enter the desired channel number or frequency value and press **Enter** (for channel numbers) or a units key—**GHz**, **MHz**, **kHz**, or **Hz** (for frequency values).

NOTE

If the desired RF Channel or Channel Freq has been set for a previous measurement, it is used for all subsequent measurements, and it does not need to be set again.

Setting a temporary center frequency does not affect any other measurement and the measurement reverts to the Channel Frequency on restart.

7. Turn on the RF Tracking Generator by pressing **Source** and then **Amplitude** until **On** is underlined.
8. Set an amplitude level appropriate for the device under test. The default value is -10 dBm. For systems with higher loss, you may use 0 dBm.
9. Normalize the measurement by pressing **View/Trace**, **More**, **Normalize**, **Store Ref (1→3)**, and **Normalize** until **On** is underlined.

Measurement

1. Ensure that the base transceiver station is in service.
2. Connect the tracking generator, signal separation device, device being measured, and the spectrum analyzer input as shown in [Figure 3-27](#).

Figure 3-30 Measurement Setup

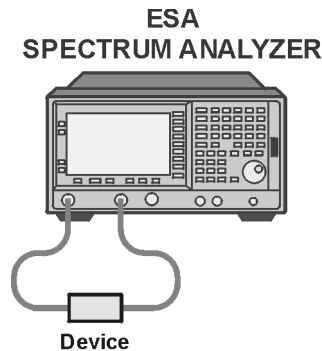

bl79b

3. Set the view to Trace 3 by pressing **View/Trace**, **Trace 3**, and **Blank**.
4. Use the marker to locate any reflected signal by pressing **Peak Search**.
5. To save the measurement results, refer to *ESA Spectrum Analyzers User's Guide*.

Results

Some of the energy incident upon a device can be reflected back towards the source. A return loss measurement quantifies this reflected energy. This measurement provides a relative measure of the transmission power that is being reflected back to the transmitter.

Figure 3-31 Example loss/gain measurement for a bandpass filter

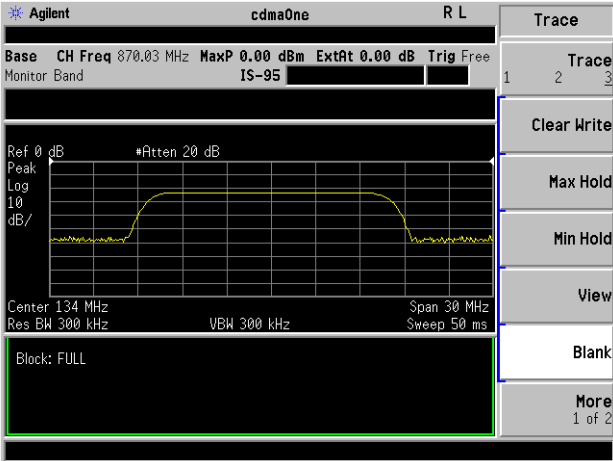

Troubleshooting Hints

If you do not obtain the expected results, repeat the setup procedure to check the integrity of the test connections.

Available Advanced cdmaOne Measurements

The following advanced cdmaOne base transceiver station measurements are described in this chapter:

- ❑ Code Domain Power on [page 4-3](#)
- ❑ Modulation Accuracy (Rho) on [page 4-8](#)
- ❑ Spur Close on [page 4-13](#)
- ❑ Out of Band Spurious on [page 4-18](#)
- ❑ Receiver Spurious on [page 4-23](#)
- ❑ Spurs at Harmonics on [page 4-29](#)

These are referred to as one-button measurements. When you press the key to select the measurement it will become the active measurement, using settings and a display unique to that measurement. Data acquisitions will automatically begin provided trigger requirements, if any, are met.

In addition, the following spectrum analyzer mode measurements are described in this chapter to provide thorough cdmaOne base transceiver station troubleshooting:

- ❑ Microwave Transmitter Power on [page 4-33](#)
- ❑ Microwave Spectrum Monitoring on [page 4-36](#)
- ❑ Microwave Adjacent Channel Power (ACP) on [page 4-39](#)

Making the Code Domain Measurement (Base Station Only)

Purpose

This measurement determines the power associated with each Walsh code (0 to 63). The traffic channel and paging channel measured powers are given relative to the pilot channel. The power measured in the inactive traffic channels is primarily the excess noise in the system. This noise can either come from the power in Walsh channels that are not correlated or from excess noise generated in the UUT. Poor code domain performance will result in lost calls and degraded signal quality.

Measurement Method

You can make the Code Domain measurement intrusively or non-intrusively. To perform a non-intrusive test, connect a directional coupler to the RF output with the main arm connected to the antenna and the coupled port connected to the spectrum analyzer as shown in [Figure 4-1](#). Enter the loss due to the effect of the coupler as external attenuation. You may also perform a non-intrusive test by making the measurement at a test port on the transceiver unit, if available.

You can use the intrusive method by taking the measurement directly from the RF output port of the transceiver, as shown in [Figure 4-2](#). Because you disconnect the antenna from the transceiver and disrupt the transmission signal, this cannot be considered a non-intrusive test. The transceiver will not be able to communicate with users on the system.

NOTE	Use of a non-intrusive measurement is recommended.
-------------	--

CAUTION	If you use the intrusive method, ensure that the power level at the RF input of the spectrum analyzer does not exceed the damage level of 30 dBm.
----------------	---

Measurement Hints

The time bases of the base station and the spectrum analyzer should be locked together.

Making the Measurement

1. Ensure that the base transceiver station is in service.
2. Connect the device being measured and the spectrum analyzer input as shown in [Figure 4-1](#) or [Figure 4-2](#).

Figure 4-1 Measurement Setup

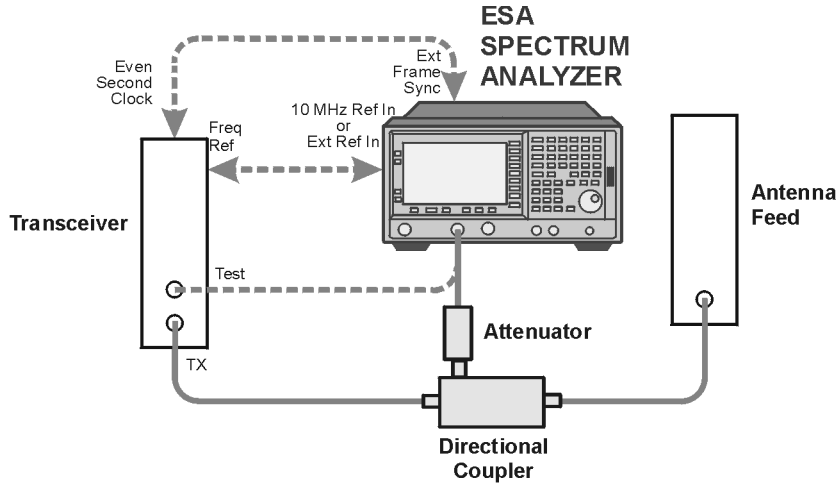

* Use Attenuator to protect the instruments if RF power exceed 30dBm.

b1719b

Figure 4-2 Alternative Measurement Setup

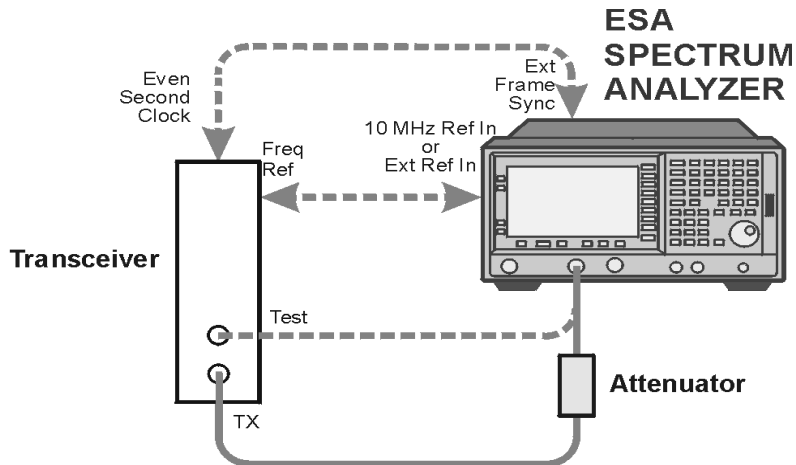

* Use Attenuator to protect the instruments if RF power exceed 30dBm.

b1724b

3. If the mode has not already been set to cdmaOne, press **MODE** and **cdmaOne**.
4. Ensure that the correct Standard is selected by pressing **Mode Setup** and **Radio**....
5. To immediately make Code Domain Power the active measurement, press **MEASURE** and **Code Domain Power**.
6. Select the desired center frequency by pressing **FREQUENCY**, then press the appropriate menu key **RF Channel**, **Channel Freq**, or **Temp Ctr Freq**. Enter the desired channel number or frequency value and press **Enter** (for channel numbers) or a units key—**GHz**, **MHz**, **kHz**, or **Hz** (for frequency values).

NOTE

If the desired RF Channel or Channel Freq has been set for a previous measurement, it is used for all subsequent measurements, and it does not need to be set again.

Setting a temporary center frequency does not affect any other measurement, and the measurement reverts to the Channel Frequency on restart.

7. Set the measurement parameters to the default values by pressing **Meas Setup**, **More** and **Restore Meas Defaults**.

NOTE

The factory default settings provide a measurement compliant with the selected standard. For special requirements, you may need to change some of the settings. At any time, you can return all parameters for the current measurement to the default settings by repeating this step.

8. If desired, set the measurement limits to On by pressing **Meas Setup**, **More**, and **Limits**.
9. To change any of the measurement parameters from the factory default values, press the **Meas Setup** key to access menus that allow you to modify the parameters for this measurement. For additional information on keys to access measurement parameters, refer to the *Front-Panel Key Reference* section of the *ESA-E Series Spectrum Analyzers cdmaOne Measurement Personality User's Guide* or use the on screen help.
10. To save the measurement results, refer to *ESA-E Series Spectrum Analyzers cdmaOne Measurement Personality User's Guide*.

Results

The two results that should be observed closely are the “active traffic” and “inactive traffic” level. If the inactive traffic levels are high relative to the pilot channel, this could indicate excess noise in the system. This could be caused by an I/Q problem that has the effect of not modulating the carrier efficiently. A second cause of this could be a power amplifier problem that results in the amplifier being driven into compression.

Figure 4-3

Code Domain Measurement Results—Power Graph and Metrics View

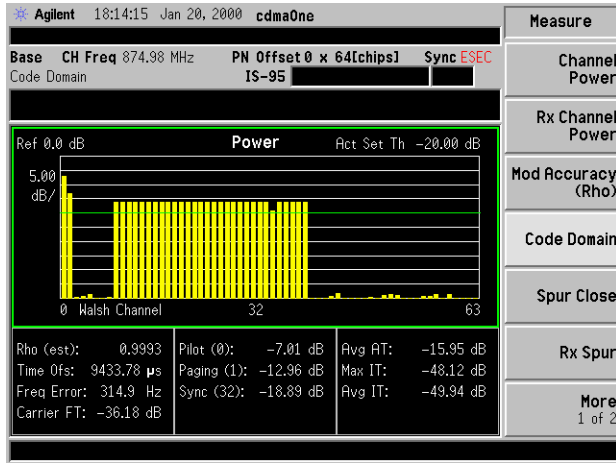

Figure 4-4

Code Domain Measurement Results—Power, Timing, and Phase View

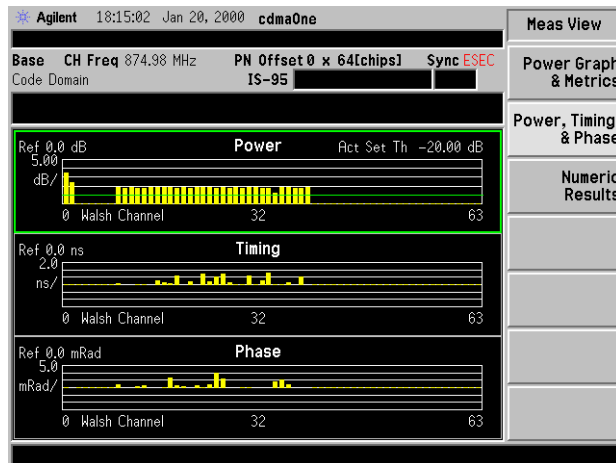
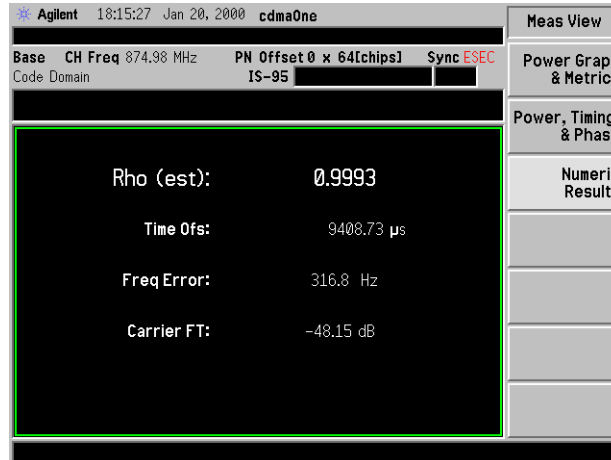

Figure 4-5 Code Domain Measurement Results—Numeric Results View



Troubleshooting Hints

High power in the inactive traffic channels (Avg IT) can indicate there is an interfering signal present. Also, poor linear amplifier performance can cause this type of effect.

Figure 4-6 Code Domain Noise

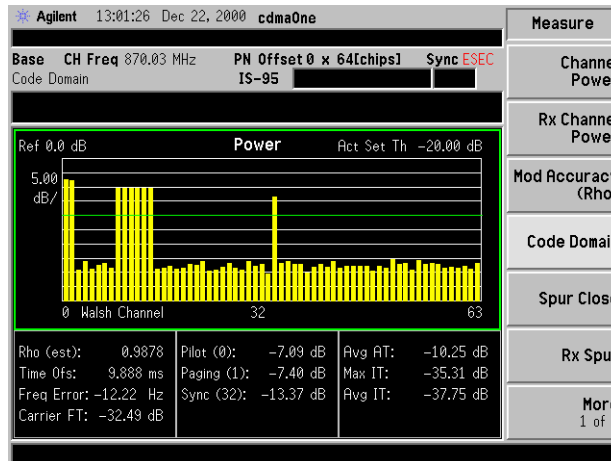

Making the Modulation Accuracy (Rho) Measurement

Purpose

Rho is the ratio of correlated power to the total power transmitted. The correlated power is computed by removing frequency phase and time offsets, and performing a cross correlation between the corrected measured signal and the ideal reference. If some of the transmitted energy does not correlate, this excess appears as added noise that may interfere with other users on the system.

Measurement Method

You can only make the rho measurement intrusively. When you perform the rho measurement a carrier channel with a single pilot channel are the only allowed active channels, and no other traffic channels or paging channels may be present. (An estimated rho can be measured non-intrusively by performing the code domain power measurement.)

The intrusive method takes the measurement directly from the RF output port of the transceiver, as shown in [Figure 4-7](#). Because you disconnect the antenna from the transceiver and disrupt the transmission signal, this cannot be considered a non-intrusive test. The transceiver will not be able to communicate with users on the system.

You may also make an intrusive test by connecting a directional coupler to the RF output with the main arm connected to the antenna and the coupled port connected to the spectrum analyzer, as shown in [Figure 4-8](#). You must ensure that only the pilot Walsh channel is active. Because only a pilot channel will be observed, the transceiver will not be able to communicate with users on the system.

CAUTION

If you take the measurement directly from the RF output port of the transceiver, ensure that the power level at the RF input of the spectrum analyzer does not exceed the damage level of 30 dBm.

Measurement Hint

The time bases of the base station and the spectrum analyzer should be locked together.

Making the Measurement

1. Ensure that the base transceiver station is in service with only the pilot Walsh channel active.
2. Connect the device being measured and the spectrum analyzer input as shown in [Figure 4-7](#) or [Figure 4-8](#).

Figure 4-7 Measurement Setup

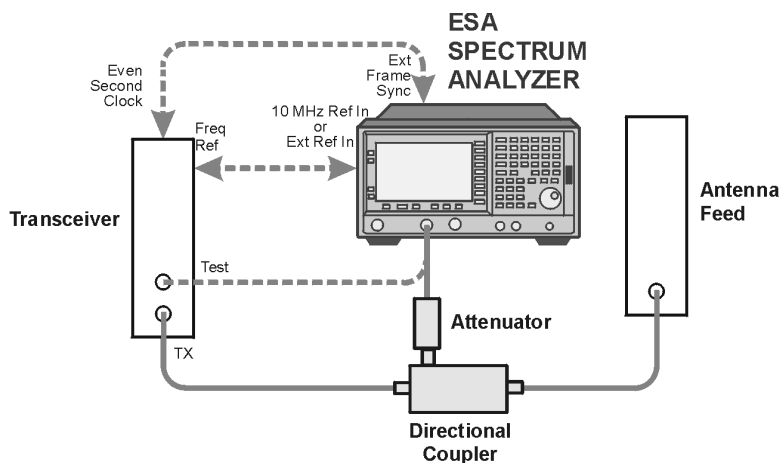

* Use Attenuator to protect the instruments if RF power exceed 30dBm.

bl719b

Figure 4-8 Alternative Measurement Setup

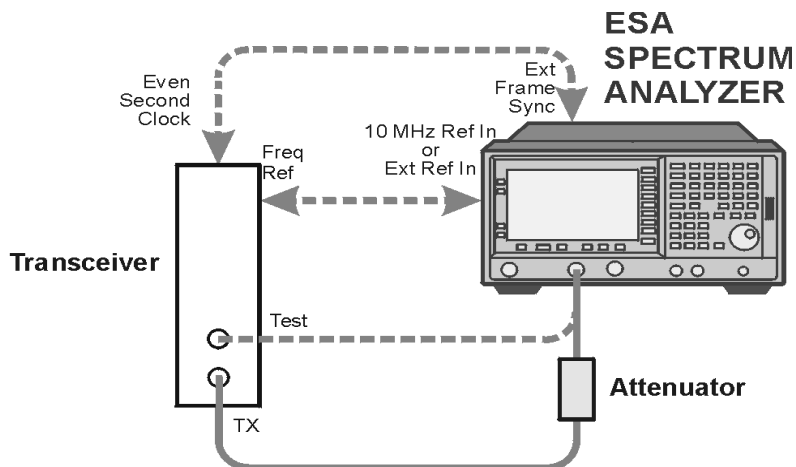

* Use Attenuator to protect the instruments if RF power exceed 30dBm.

bl724b

3. Ensure that the correct Standard is selected by pressing **Mode Setup** and **Radio....**

4. Ensure that the transmitter channel to be measured has only the pilot Walsh channel active.
5. If the mode has not already been set to cdmaOne, press **MODE** and **cdmaOne**.
6. To immediately make Modulation Accuracy (Rho) the active measurement, press **MEASURE** and **Mod Accuracy (Rho)**.
7. Select the desired center frequency by pressing **FREQUENCY**, then press the appropriate menu key **RF Channel**, **Channel Freq**, or **Temp Ctr Freq**. Enter the desired channel number or frequency value and press **Enter** (for channel numbers) or a units key—**GHz**, **MHz**, **kHz**, or **Hz** (for frequency values).

NOTE

If the desired RF Channel or Channel Freq has been set for a previous measurement, it is used for all subsequent measurements, and it does not need to be set again.

Setting a temporary center frequency does not affect any other measurement, and the measurement reverts to the Channel Frequency on restart.

8. Set the measurement parameters to the default values by pressing **Meas Setup**, **More** and **Restore Meas Defaults**.

NOTE

The factory default settings provide a measurement compliant with the selected standard. For special requirements, you may need to change some of the settings. At any time, you can return all parameters for the current measurement to the default settings by repeating this step.

9. If desired, set the measurement limits to On by pressing **Meas Setup**, **More**, and **Limits**.
10. To change any of the measurement parameters from the factory default values, press the **Meas Setup** key to access menus that allow you to modify the parameters for this measurement. For additional information on keys to access measurement parameters, refer to the *Front-Panel Key Reference* section of the *ESA-E Series Spectrum Analyzers cdmaOne Measurement Personality User's Guide* or use the on screen help.
11. To save the measurement results, refer to *ESA-E Series Spectrum Analyzers cdmaOne Measurement Personality User's Guide*.

Results

A poor rho result indicates that there is excess noise in the system. This will effect the capacity of the cell and overall signal quality.

Figure 4-9 Rho Measurement Results—I/Q Measured Compl Vector View

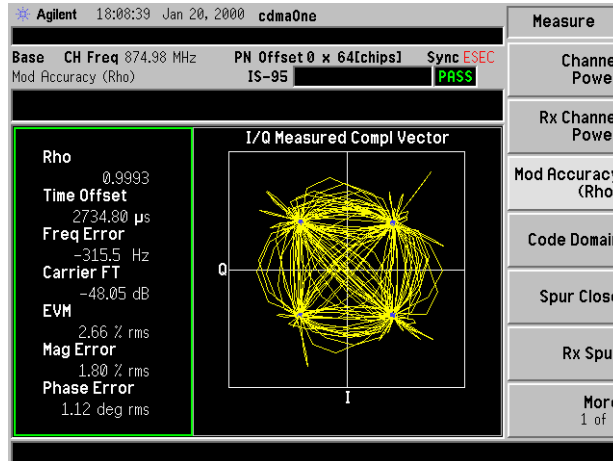
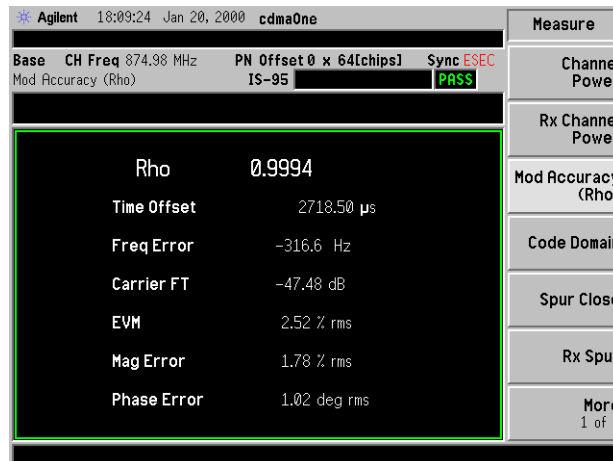

Figure 4-10 Rho Measurement Results—Numeric Results View



Troubleshooting Hints

- Circles in the constellation indicate an interfering signal. If the signal is modulated there will be no holes in the circles. This also indicates a poor signal to noise ratio.

Figure 4-11 Modulation Interference

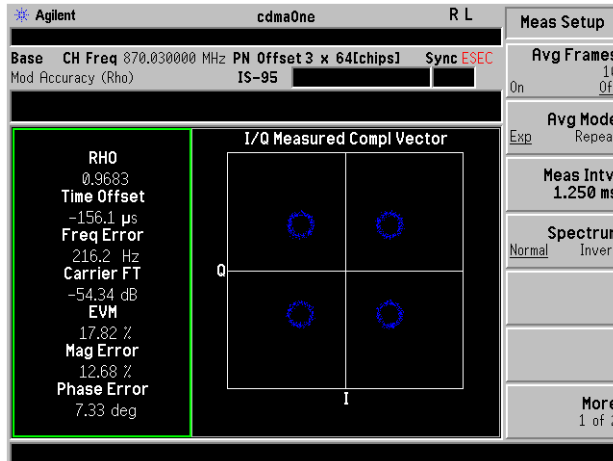

- An offset constellation or I/Q imbalance indicate a gain or phase problem with the modulator.

Figure 4-12 I/Q Imbalance

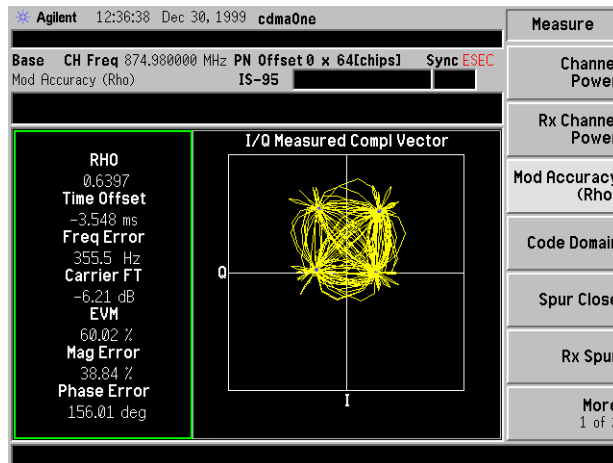

Making the Spur Close (In Band Spurious) Measurement

Purpose

Spurious signals can be caused by different combinations of signals in the transmitter. The spurious emissions from the transmitter that fall within the system band (in band spurs) should be within the level specified by the standard to guarantee minimum interference with other frequency channels in the system.

Measurement Method

You can make the spur close measurement intrusively or non-intrusively. To perform a non-intrusive test, connect a directional coupler to the RF output with the main arm connected to the antenna and the coupled port connected to the spectrum analyzer as shown in [Figure 4-13](#). Enter the loss due to the effect of the coupler as external attenuation. You may also perform a non-intrusive test by making the measurement at a test port on the transceiver unit, if available.

You can use the intrusive method by taking the measurement directly from the RF output port of the transceiver as shown in [Figure 4-14](#). Because you disconnect the antenna from the transceiver and disrupt the transmission signal, this cannot be considered a non-intrusive test. The transceiver will not be able to communicate with users on the system.

NOTE Use of a non-intrusive measurement is recommended.

CAUTION If you use the intrusive method, ensure that the power level at the RF input of the spectrum analyzer does not exceed the damage level of 30 dBm.

NOTE All limits are set assuming a 30 kHz RBW is used.

Making the Measurement

1. Ensure that the base transceiver station is in service.
2. Connect the device being measured and the spectrum analyzer input as shown in [Figure 4-13](#) or [Figure 4-14](#).

Figure 4-13 Measurement Setup

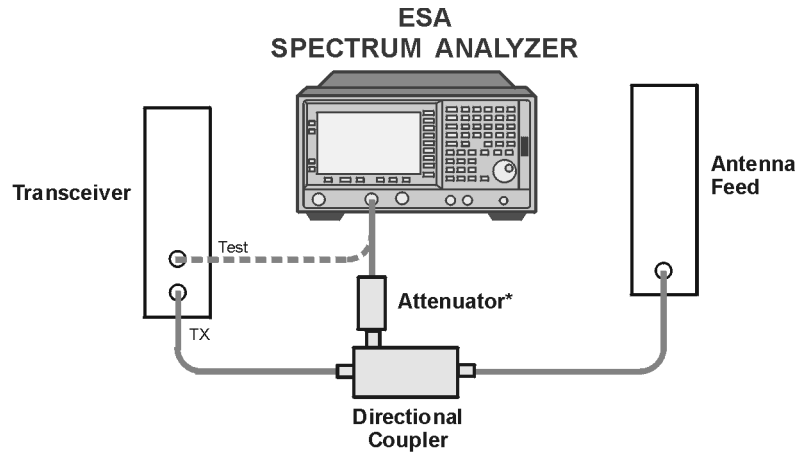

* Use Attenuator to protect the instruments if RF power exceed 30dBm.

bl718b

Figure 4-14 Alternative Measurement Setup

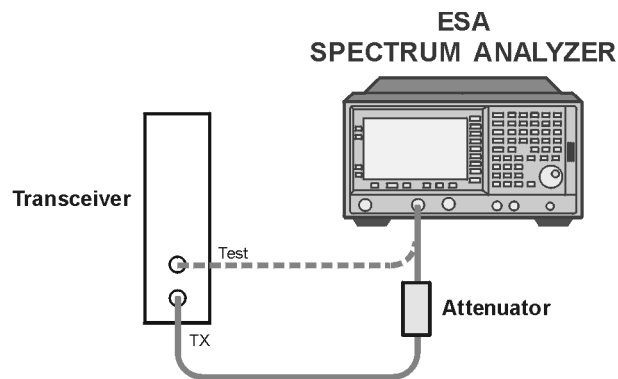

* Use Attenuator to protect the instruments if RF power exceed 30dBm.

bl720b

3. If the mode has not already been set to cdmaOne, press **MODE** and **cdmaOne**.
4. To immediately make Close-In Spurious the active measurement, press **MEASURE** and **Spur Close**.

5. Select the desired center frequency by pressing **FREQUENCY**, then press the appropriate menu key (**RF Channel** or **Channel Freq**), enter the desired channel number or frequency value and press **Enter** (for channel numbers) or a units key—**GHz**, **MHz**, **kHz**, or **Hz** (for frequency values).

NOTE

If the desired RF Channel or Channel Freq has been set for a previous measurement, it is used for all subsequent measurements, and it does not need to be set again.

6. Set the measurement parameters to the default values by pressing **Meas Setup**, **More** and **Restore Meas Defaults**.

NOTE

The factory default settings provide a measurement compliant with the selected standard. For special requirements, you may need to change some of the settings. At any time, you can return all parameters for the current measurement to the default settings by repeating this step.

7. If desired, set the measurement limits to Off by pressing **Meas Setup**, **More**, and **Limits**.
8. To change any of the measurement parameters from the factory default values, press the **Meas Setup** key to access menus that allow you to modify the parameters for this measurement. For additional information on keys to access measurement parameters, refer to the *Front-Panel Key Reference* section of the *ESA-E Series Spectrum Analyzers cdmaOne Measurement Personality User's Guide* or use the on screen help.
9. To save the measurement results, refer to *ESA-E Series Spectrum Analyzers cdmaOne Measurement Personality User's Guide*.

Results

Figure 4-15 shows an example of the channel power portion of the measurement results with the **Meas Type** set to **Full**. The display cycles through the channel power, lower, upper, and center segment views during the measurement.

Figure 4-15 Spur Close Measurement Results—IS-95A - Channel Power

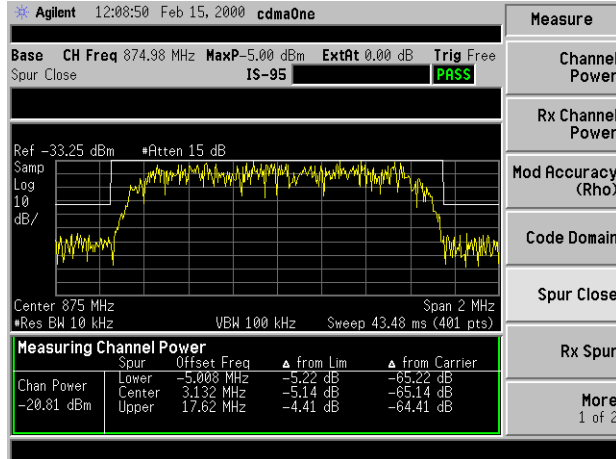
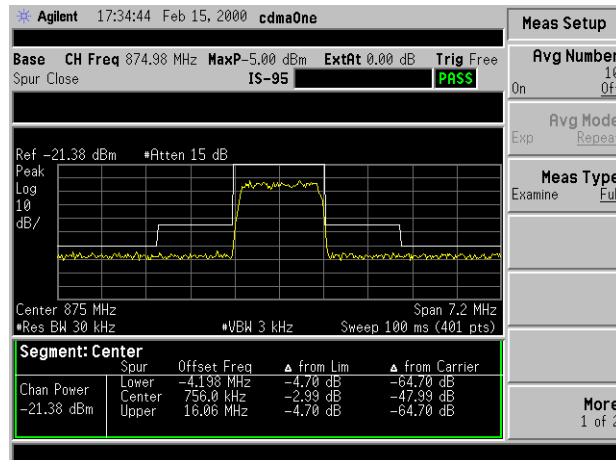

Figure 4-16 shows an example of the Center Segment results. The display cycles through the channel power, lower, upper, and center segment views during the measurement.

Figure 4-16 Spur Close Measurement Results—IS-95A - Center



Troubleshooting Hint

If an external attenuator is used, be sure to include the attenuation value in the measurement. This can be done by entering the **BS Ext Atten** under the **Input/Output** front panel key or the **Input...** key on the **Mode Setup** menu.

Making the Out of Band Spurious Measurement

Purpose

This measurement will help verify that the transmitter meets regulatory standards for emissions and that the transmitter is not contributing to interference outside of the specified transmit band.

Measurement Method

The table-driven measurement has the flexibility to set up custom parameters such as frequency, span, resolution bandwidth, and video bandwidth. Up to the top 10 spurs can be viewed

You can make the Out of Band Spurious measurement intrusively or non-intrusively. To perform a non-intrusive test, connect a directional coupler to the RF output with the main arm connected to the antenna and the coupled port connected to the spectrum analyzer as shown in [Figure 4-17](#). Enter the loss due to the effect of the coupler as external attenuation. You may also perform a non-intrusive test by making the measurement at a test port on the transceiver unit, if available.

You can use the intrusive method by taking the measurement directly from the RF output port of the transceiver as shown in [Figure 4-18](#). Because you disconnect the antenna from the transceiver and disrupt the transmission signal, this cannot be considered a non-intrusive test. The transceiver will not be able to communicate with users on the system.

NOTE	Use of a non-intrusive measurement is recommended.
-------------	--

CAUTION	If you use the intrusive method, ensure that the power level at the RF input of the spectrum analyzer does not exceed the damage level of 30 dBm.
----------------	---

Measurement Hints

- Use large resolution bandwidth for fast measurements, and a narrow resolution bandwidth for increased sensitivity.
- Generally the frequency ranges that are prone to spurious emissions are known. If they are unknown set wide frequency ranges.
- The measured channel power value used for the relative measurements can be viewed at the top of the display.

Making the Measurement

1. Ensure that the base transceiver station is in service.
2. Connect the device being measured and the spectrum analyzer input as shown in [Figure 4-17](#) or [Figure 4-18](#).

Figure 4-17 Measurement Setup

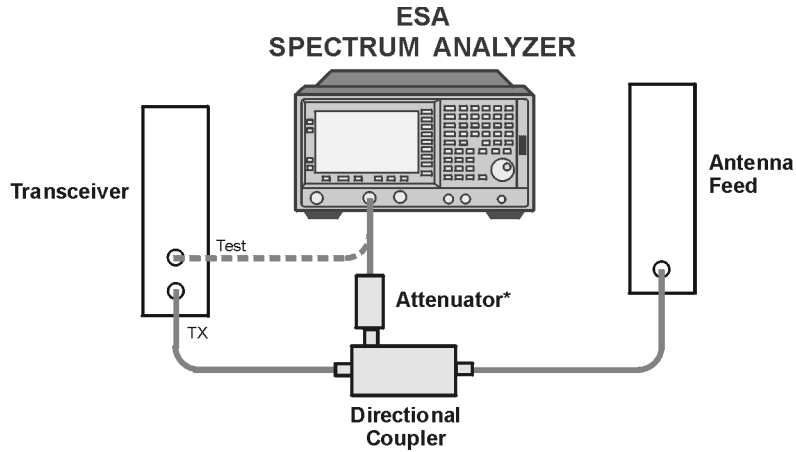

* Use Attenuator to protect the instruments if RF power exceed 30dBm.

b1718b

Figure 4-18 Alternative Measurement Setup

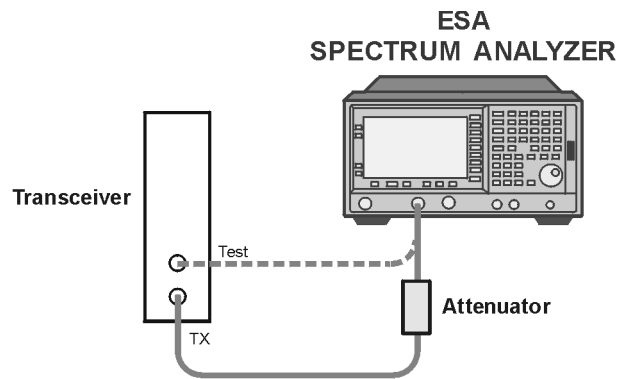

* Use Attenuator to protect the instruments if RF power exceed 30dBm.

b1720b

3. If the mode has not already been set to cdmaOne, press **MODE** and **cdmaOne**.
4. To immediately make Out of Band Spurious the active measurement, press **MEASURE**, **More**, and **Out of Band Spurious**.
5. Select the desired transmit channel frequency by pressing **FREQUENCY**, then press the appropriate menu key (**RF Channel** or **Channel Freq**), enter the desired channel number or frequency value and press **Enter** (for channel numbers) or a units key—**GHz**, **MHz**, **kHz**, or **Hz** (for frequency values).

NOTE

If the desired RF Channel or Channel Freq has been set for a previous measurement, it is used for all subsequent measurements, and it does not need to be set again.

6. Set the measurement parameters to the default values by pressing **Meas Setup**, **More** and **Restore Meas Defaults**.

NOTE

The factory default settings provide a measurement compliant with the selected standard. For special requirements, you may need to change some of the settings. At any time, you can return all parameters for the current measurement to the default settings by repeating this step.

7. If desired, you may edit the spurs table or simply use the default table.

Editing a Spurs Table

- a. Press **Meas Setup**, **Edit Table...**, and then select the range you wish to edit.
- b. Press **Tab** |← and →| or the menu keys to navigate between data fields.
- c. Enter the desired values and press **Enter**.
- d. To end editing and close the table, press **Return** or any hard key. The measurement will restart using the customized table.

Saving a Customized Spurs Table

- a. After you complete the table edits, press **Save Table**.

Loading a Customized Spurs Table

- a. To load the customized table that was saved last, press **Meas Setup**, **Edit Table...**, and **Load Table**.

8. To change any of the measurement parameters from the factory default values, press the **Meas Setup** key to access menus that allow you to modify the parameters for this measurement. For additional information on keys to access measurement parameters, refer to the *Front-Panel Key Reference* section of the *ESA-E Series Spectrum Analyzers cdmaOne Measurement Personality User's Guide* or use the on screen help.
9. To save the measurement results, refer to *ESA-E Series Spectrum Analyzers cdmaOne Measurement Personality User's Guide*.

Results

The cdmaOne specification states that the total spurious emissions outside the allocated system band including harmonics (in a 30 kHz resolution bandwidth) should not exceed 60 dB below the mean output channel bandwidth or -13 dBm, whichever is smaller. For this reason limits can be set as both relative to the carrier and to absolute values.

Figure 4-19 shows the tabular view of the Out of Band Spurious measurement results. The test column in the data table indicates that the range one spurs did not meet the test limit criteria.

Figure 4-19

Tabular Results View with Spur Failures

Agilent 13:25:52 Feb 22, 2001 cdmaOne							Measure
Base CH Freq 870.03 MHz MaxP -20.00 dBm ExtAt 0.00 dB Trig Free							Spurs at Harmonics
Out of Band Spurious IS-95 FAIL							Out of Band Spurious
Channel Power -80.04 dBm							Occupied BW
Range	Spur	Frequency	Amplitude	Δ Rel Limit	Δ Abs Limit	Test	Monitor Band/Channel
1	1	299.5 MHz	-57.94 dBm	102.10 dB	2.06 dB	Fail	
1	2	300.5 MHz	-58.93 dBm	101.11 dB	1.07 dB	Fail	
1	3	300.1 MHz	-59.48 dBm	100.56 dB	0.52 dB	Fail	
1	4	300.3 MHz	-59.71 dBm	100.32 dB	0.29 dB	Fail	
1	5	300.3 MHz	-61.94 dBm	98.09 dB	-1.94 dB	Fail	
2	1	604.2 MHz	-89.55 dBm	70.48 dB	-29.55 dB	Fail	
2	2						
2	3						
2	4						
2	5						
3	1	896.1 MHz	-90.83 dBm	69.21 dB	-30.83 dB	Fail	
3	2						
3	3						
3	4						
3	5						

More
2 of 2

Troubleshooting Hints

- If an external attenuator is used, be sure to include the attenuation value in the measurement. This can be done by entering the **BS Ext Atten** under the **Input/Output** front panel key or the **Input...** key on the **Mode Setup** menu.
- To determine if spurious signals are generated internally by the ESA, increment the attenuator increasing the attenuation. If the spurious signals decrease in amplitude, then the signals are generated by the analyzer.
- In order to reduce out of band spurs, it might be necessary to reduce the power of the transmitter.

Making the Receiver Spurious (Rx Spur) Measurement

Purpose

This measurement verifies that the receiver bands are free of interference by measuring the spurious signals in the receiver channel bandwidth specified by the selected standard and tuning plan. For proper transceiver functionality, it is important that there is no interference in the receive band. The receiver spurious measurement will sweep the receive band and report the three strongest signals. This measurement can also be used to sweep the transmit band for spurious signals by setting the band to Tx under **Meas Setup**.

Measurement Method

This procedure sweeps the specified transmitter or receiver frequency block. If a carrier or strong signal is detected, the measurement will be terminated until the carrier is turned off or removed. After determining that there are no carriers present, the three highest peaks (if found) are reported.

To improve repeatability, you can increase the number of averages.

You can make the Rx Spur measurement intrusively or non-intrusively. To perform a non-intrusive test, connect a directional coupler to the RF output with the main arm connected to the antenna and the coupled port connected to the spectrum analyzer as shown in [Figure 4-20](#). Enter the loss due to the effect of the coupler as external attenuation. You may also perform a non-intrusive test by making the measurement at a test port on the transceiver unit, if available.

You can use the intrusive method by taking the measurement directly from the RF output port of the transceiver as shown in [Figure 4-21](#). Because you disconnect the antenna from the transceiver and disrupt the transmission signal, this cannot be considered a non-intrusive test. The transceiver will not be able to communicate with users on the system.

NOTE Use of a non-intrusive measurement is recommended.

CAUTION If you use the intrusive method, ensure that the power level at the RF input of the spectrum analyzer does not exceed the damage level of 30 dBm.

Measurement Hints

A band pass filter can be inserted in between the transmitter and the spectrum analyzer to filter out the carrier, this will maximize dynamic range.

Making the Measurement

1. Ensure that the base transceiver station is out of service.
2. Connect the device being measured and the spectrum analyzer input as shown in [Figure 4-20](#) or [Figure 4-21](#).

Figure 4-20 Measurement Setup

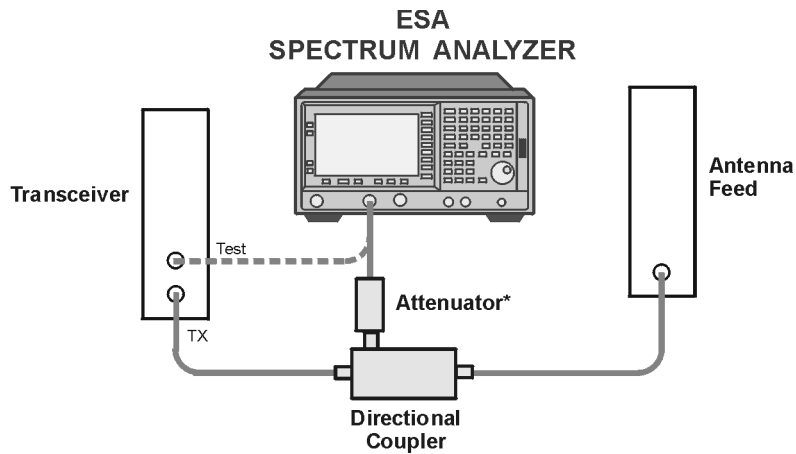

* Use Attenuator to protect the instruments if RF power exceed 30dBm.

b1718b

Figure 4-21 Alternative Measurement Setup

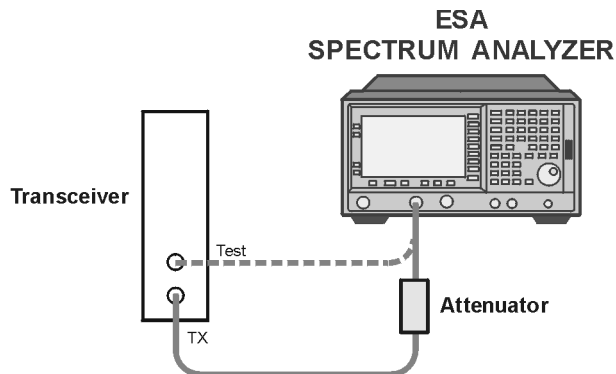

* Use Attenuator to protect the instruments if RF power exceed 30dBm.

b1720b

3. If the mode has not already been set to cdmaOne, press **MODE** and **cdmaOne**.
4. To immediately make Receiver Spurious the active measurement, press **MEASURE** and **Rx Spur**. The Preamp dialog box shown in [Figure 4-22](#) will be displayed.

Figure 4-22 Preamp Dialog Box

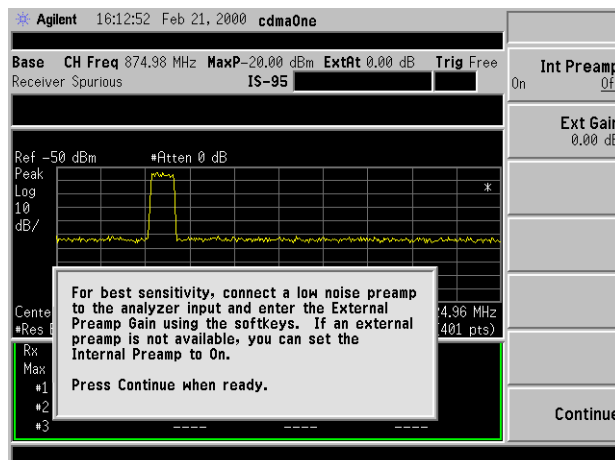

NOTE

If there is no internal preamplifier Option 1DS installed the message will read as follows: "For best sensitivity, connect a low noise preamp to the analyzer input. Set the External Preamp Gain using the softkeys. Press Continue when ready."

5. To continue follow the instructions in the dialog box and then press **Continue**. The attenuation caution dialog box shown in [Figure 4-23](#) will be displayed.

Figure 4-23 Attenuation Dialog Box

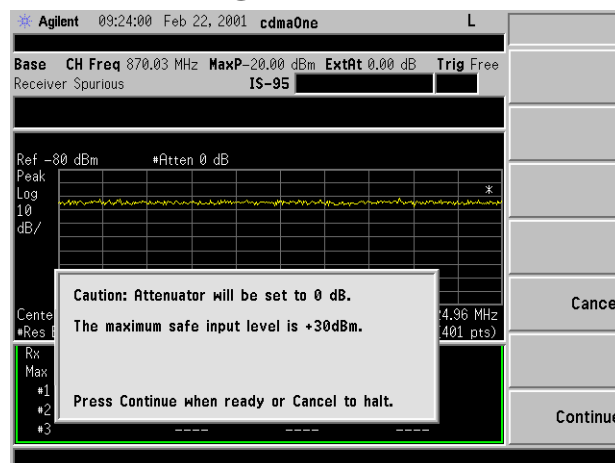

6. Set the input signal level according to the instructions in the dialog box. Then, press **Continue** to continue with the measurement or press **Cancel** to terminate the measurement without setting the attenuation to 0 dB.
7. Select the desired center frequency by pressing **FREQUENCY**, then press the appropriate menu key (**RF Channel** or **Channel Freq**), enter the desired channel number or frequency value and press **Enter** (for channel numbers) or a units key—**GHz**, **MHz**, **kHz**, or **Hz** (for frequency values).

NOTE

If the desired RF Channel or Channel Freq has been set for a previous measurement, it is used for all subsequent measurements, and it does not need to be set again.

8. Set the measurement parameters to the default values by pressing **Meas Setup**, **More** and **Restore Meas Defaults**.

NOTE

The factory default settings provide a measurement compliant with the selected standard. For special requirements, you may need to change some of the settings. At any time, you can return all parameters for the current measurement to the default settings by repeating this step.

9. If desired, set the measurement limits to On by pressing **Meas Setup**, **More**, and **Limits**.
10. To change any of the measurement parameters from the factory default values, press the **Meas Setup** key to access menus that allow you to modify the parameters for this measurement. For additional information on keys to access measurement parameters, refer to the *Front-Panel Key Reference* section of the *ESA-E Series Spectrum Analyzers cdmaOne Measurement Personality User's Guide* or use the on screen help.
11. To save the measurement results, refer to *ESA-E Series Spectrum Analyzers cdmaOne Measurement Personality User's Guide*.

Results

The three largest spurs in the range of interest will be reported. Both the transmit and receive band can be investigated. It is possible to choose from a number of different blocks for a specific standard.

Figure 4-24 shows the standard view of the receiver spurious measurement with four spurious signals in the spectrum. The frequency, absolute power and the power relative to the measurement limit for the three largest spurs are tabulated below the trace display. Figure 4-25 shows the active trace view for the same measurement results. However, the data for only the single largest spur and the marker are tabulated below the trace display. In Figure 4-26 the numeric measurement results data for the three largest spurs are tabulated with the measurement parameters.

Figure 4-24 Standard Results

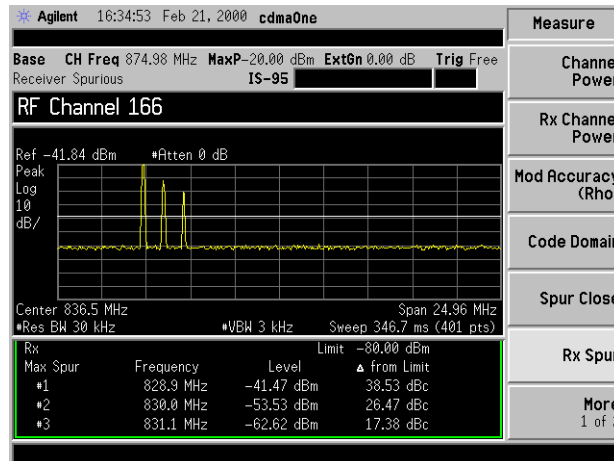

Figure 4-25 Active Trace Results

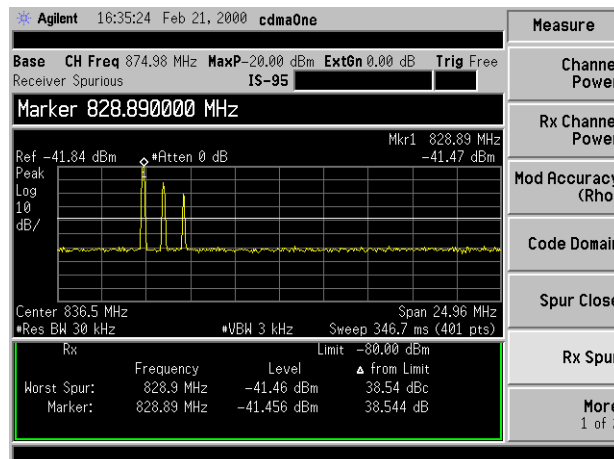
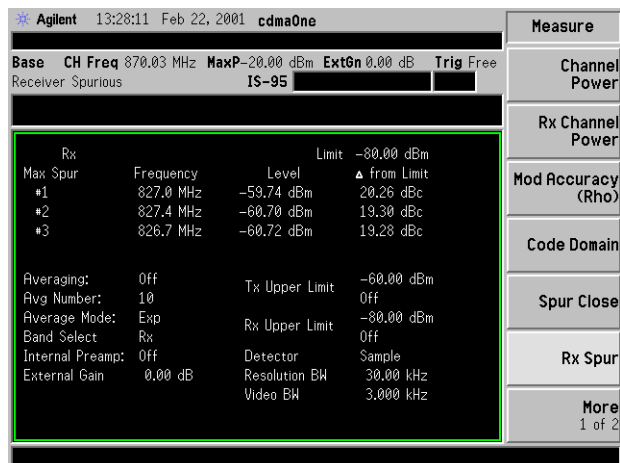

Figure 4-26 **Numeric Plus Parameters Results**



Troubleshooting Hints

- Excessive interference in the receive band will cause system problems. Minimize any interference.
- If an external preamplifier is used, be sure to include the gain value in the measurement. This can be done by entering the **External Gain** under the **Input/Output** front panel key or the **Input...** key on the **Mode Setup** menu.
- To determine if spurious signals are generated internally by the ESA, increase the attenuation. If the spurious signals change in amplitude, then the signals are generated by the analyzer.

Making the Spurs at Harmonics Measurement

Purpose

Spurious signals can be caused by different combinations of signals in the transmitter. The spurious emissions from the transmitter that fall within the system band should be within the level specified by the standard to guarantee minimum interference with other frequency channels in the system. Harmonics are distortion products caused by nonlinear behavior in the transmitter. They are integer multiples of the transmitted signal carrier frequency.

Measurement Method

You can make the Spurs at Harmonics measurement intrusively or non-intrusively. To perform a non-intrusive test, connect a directional coupler to the RF output with the main arm connected to the antenna and the coupled port connected to the spectrum analyzer as shown in [Figure 4-27](#). Enter the loss due to the effect of the coupler as external attenuation. You may also perform a non-intrusive test by making the measurement at a test port on the transceiver unit, if available.

You can use the intrusive method by taking the measurement directly from the RF output port of the transceiver as shown in [Figure 4-28](#). Because you disconnect the antenna from the transceiver and disrupt the transmission signal, this cannot be considered a non-intrusive test. The transceiver will not be able to communicate with users on the system.

NOTE	Use of a non-intrusive measurement is recommended.
-------------	--

CAUTION	If you use the intrusive method, ensure that the power level at the RF input of the spectrum analyzer does not exceed the damage level of 30 dBm.
----------------	---

Measurement Hints

- Use large resolution bandwidth for fast measurements, and a narrow resolution bandwidth for increased sensitivity. For testing to the specification, use a 1 MHz RBW.
- The Channel power used for the relative measurements can be viewed at the lower left corner of the display.

Making the Measurement

1. Ensure that the base transceiver station is in service.
2. Connect the device being measured and the spectrum analyzer input as shown in [Figure 4-27](#) or [Figure 4-28](#).

Figure 4-27 Measurement Setup

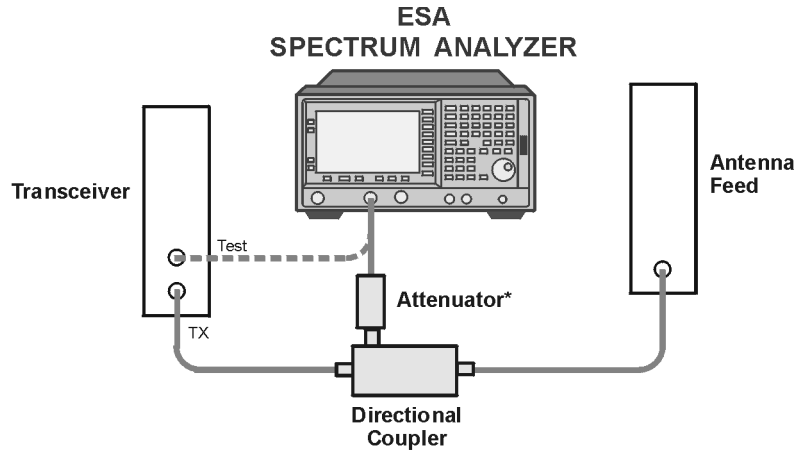

* Use Attenuator to protect the instruments if RF power exceed 30dBm.

bl718b

Figure 4-28 Alternative Measurement Setup

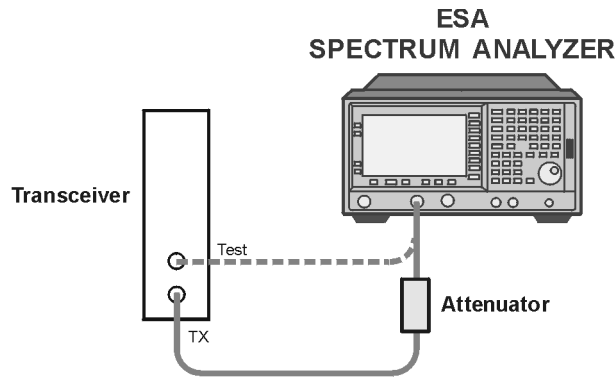

* Use Attenuator to protect the instruments if RF power exceed 30dBm.

bl720b

3. If the mode has not already been set to cdmaOne, press **MODE** and **cdmaOne**.
4. To immediately make Spurs at Harmonics the active measurement, press **MEASURE**, **More**, and **Spurs at Harmonics**.

5. Select the desired center frequency by pressing **FREQUENCY**, then press the appropriate menu key **RF Channel** or **Channel Freq**. Enter the desired channel number or frequency value and press **Enter** (for channel numbers) or a units key—**GHz**, **MHz**, **kHz**, or **Hz** (for frequency values).

NOTE

If the desired RF Channel or Channel Freq has been set for a previous measurement, it is used for all subsequent measurements, and it does not need to be set again.

6. Set the measurement parameters to the default values by pressing **Meas Setup** and **Restore Meas Defaults**.

NOTE

The factory default settings provide a measurement compliant with the selected standard. For special requirements, you may need to change some of the settings. At any time, you can return all parameters for the current measurement to the default settings by repeating this step.

7. If desired, set the measurement limits to On by pressing **Meas Setup**, **More**, and **Limits**.
8. To change any of the measurement parameters from the factory default values, press the **Meas Setup** key to access menus that allow you to modify the parameters for this measurement. For additional information on keys to access measurement parameters, refer to the *Front-Panel Key Reference* section of the *ESA-E Series Spectrum Analyzers cdmaOne Measurement Personality User's Guide* or use the on screen help.
9. To save the measurement results, refer to *ESA-E Series Spectrum Analyzers cdmaOne Measurement Personality User's Guide*.

Results

[Figure 4-24](#) shows the standard view of Spurs at Harmonics measurement. Spurs measured at the selected harmonic frequencies are shown in the trace portion of the display. Below the trace in the numeric portion of the display, the frequency and the relative and absolute power of the measured spurs are shown. The fundamental channel frequency is tuned and measured first, each harmonic frequency is tuned in secession and any spur is measured. As each frequency is measured, the trace view cycles through each frequency trace and the data table is updated.

Figure 4-29 Spurs at Harmonics Measurement Results—Standard View

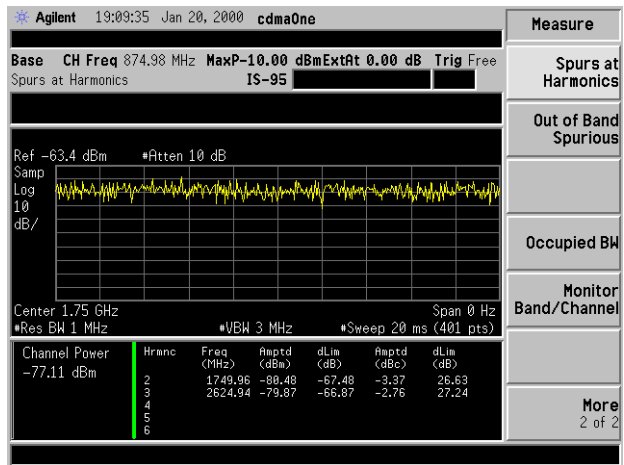

Troubleshooting Hints

- Excess harmonics level could be caused by non-linear distortion in the output power amplifier or too high of an output power. A second cause of this could be a power amplifier problem that results in the amplifier being driven into compression. Troubleshoot the output power amplifier.
- If an external attenuator is used, be sure to include the attenuation value in the measurement. This can be done by entering the **BS Ext Atten** under the **Input/Output** front panel key or the **Input...** key on the **Mode Setup** menu.
- To determine if spurious signals are generated internally by the ESA, increase the attenuation. If the spurious signals changes in amplitude, then the signals are generated by the analyzer.

Making the Microwave Transmitter Power Measurement

Purpose

This is a SA mode measurement used to verify the power in the microwave transmitter channel. The total rms power in the specified integration bandwidth is determined by this measurement.

Measurement Method

You can make the Microwave Transmit Power measurement intrusively or non-intrusively. To perform a non-intrusive test, connect a directional coupler to the RF output with the main arm connected to the antenna and the coupled port connected to the spectrum analyzer. Enter the loss due to the effect of the coupler as external attenuation. You may also perform a non-intrusive test by making the measurement at a test port on the antenna, if available.

You can use the intrusive method by taking the measurement directly from the RF output port of the transceiver. Because you disconnect the antenna from the transceiver and disrupt the transmission signal, this cannot be considered a non-intrusive test. The transceiver will not be able to communicate with users on the system.

NOTE

Use of a non-intrusive measurement is recommended.

CAUTION

If you use the intrusive method, ensure that the power level at the RF input of the spectrum analyzer does not exceed the damage level of 30 dBm.

Making the Measurement

1. Ensure that the base transceiver station microwave transmitter is in service.
2. Connect the device being measured and the spectrum analyzer input as shown in [Figure 4-30](#).

Figure 4-30

Measurement Setup

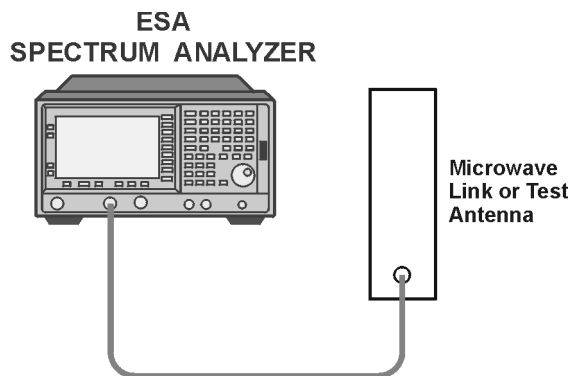

b1721b

3. Set the ESA Spectrum Analyzer to the SA mode by pressing **Mode** and **SA**.
4. Preset the ESA Spectrum Analyzer by pressing **PRESET**.
5. Activate the Channel Power measurement by pressing **MEASURE** and **Channel Power**.
6. Set the transmitter channel carrier frequency to be measured by pressing **FREQUENCY**, **Center Freq**, and then entering the frequency using the numeric keys.
7. Set the integration bandwidth by pressing **Meas Setup**, **Integration BW**, and then enter the bandwidth frequency.

Results

Figure 4-31

Example of Channel Power Measurement Results

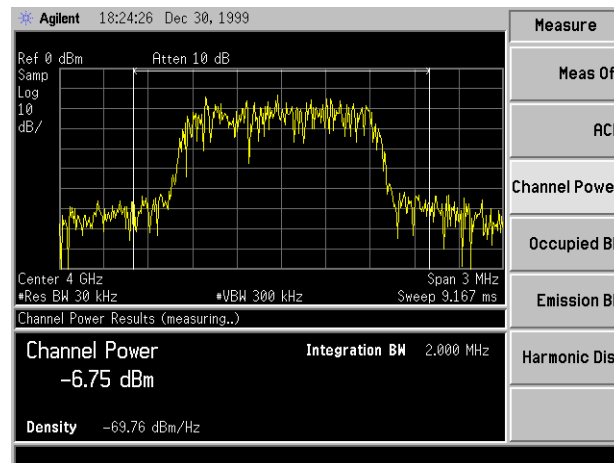

Troubleshooting Hints

- If an external attenuator is used, be sure to include the attenuation value in the measurement. This can be done by entering the **Ref Lvl Offset** under the **AMPLITUDE Y Scale** front panel key.
- If an external preamplifier is used, be sure to include the gain value in the measurement. This can be done by entering the **Ext Amp Gain** under the **AMPLITUDE Y Scale** front panel key.

Making a Microwave Spectrum Monitoring Measurement

Purpose

This is a SA mode measurement used to monitor the microwave receiver RF frequency spectrum for the presents of signals that may cause interference.

Measurement Method

You can make the Microwave Spectrum Monitoring measurement intrusively or non-intrusively. To perform a non-intrusive test, connect a directional coupler to the RF output with the main arm connected to the antenna and the coupled port connected to the spectrum analyzer. Enter the loss due to the effect of the coupler as external attenuation. You may also perform a non-intrusive test by making the measurement at a test port on the transceiver unit, if available.

CAUTION

If you use the intrusive method, ensure that the power level at the RF input of the spectrum analyzer does not exceed the damage level of 30 dBm.

Measurement Hints

- To increase measurement sensitivity, reduce the resolution bandwidth by pressing **BW/Avg**, **Resolution BW**, and then enter the bandwidth frequency. The sensitivity can also be increased by reducing the video bandwidth by pressing **BW/Avg**, **Video BW**, and then enter the bandwidth frequency.
- Use large resolution bandwidth for fast measurements, and a narrow resolution bandwidth for increased sensitivity. For testing to the specification, use a 30 kHz RBW.

Making the Measurement

1. Ensure that the microwave link is not in service.
2. Connect the device being measured and the spectrum analyzer input as shown in [Figure 4-32](#).

Figure 4-32 Measurement Setup

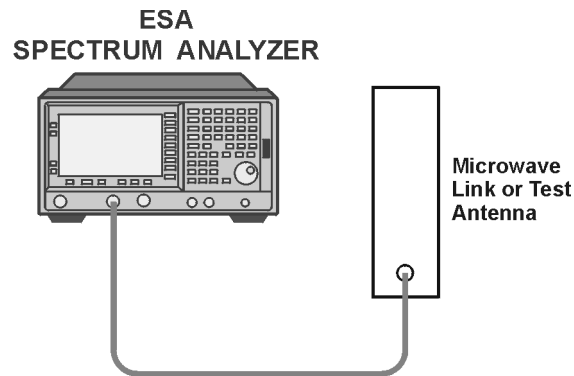

bl721b

3. Set the ESA Spectrum Analyzer to the SA mode by pressing **Mode** and **SA**.
4. Turn off all measurements by pressing **MEASURE** and **Meas Off**.
5. Set the transmitter channel carrier frequency to be measured by pressing **FREQUENCY**, **Center Freq**, and then entering the frequency to the transmitter using the numeric keys.
6. Set the microwave spectrum span by pressing **SPAN**, **Span**, and then entering the frequency using the numeric keys.
7. Set the attenuation as low as possible by pressing **AMPLITUDE Y Span**, **Attenuation**, and then entering the attenuation value in dB using the numeric keys.

NOTE

When setting the input attenuator, the resulting signal level must not be too large or small.

- If signal power is too high, it can overload the spectrum analyzer and cause ACP.
- If signal power is too low, the ACP measurement is degraded by the presence of excessive noise.

Set the attenuator to the smallest available value, in dB, that is larger than the transmitter power, in dBm, plus 10 dB.

-
8. Turn on the peak markers and data table by pressing **Peak Search**, **More**, and **Peak Table**.
 9. Turn on the marker display line by pressing **Peak Readout** and **> Display Line**.

10. Set the display line level by pressing **Display**, **Display Line**, and then entering the level in dB using the numeric keys.

The trace display will show markers

11. Set the display readout mode by pressing **Marker**, **More**, **Readout**, and **Frequency**.

12. Repeat steps 4 through 11 using the receive channel frequency to monitor the receiver spectrum.

Results

The trace display will show markers for any signal peaks found that exceed the display line level. The markers will be numbered in descending order of peak power. The source of these signals should be located and they should be removed to prevent interference with the microwave link signal.

Figure 4-33

Example of Microwave Spectrum Monitoring Results

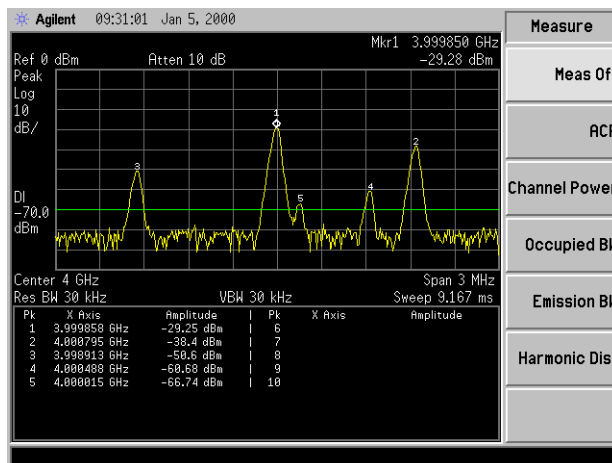

Making the Microwave Adjacent Channel Power Measurement

Purpose

This is a SA mode measurement used to verify that the transmitter meets adjacent channel power requirements. It measures the ratio of transmitted power in an adjacent channel to the power in the transmitter channel.

Measurement Method

You can make the Microwave Adjacent Channel Power measurement intrusively or non-intrusively. To perform a non-intrusive test, connect a directional coupler to the RF output with the main arm connected to the antenna and the coupled port connected to the spectrum analyzer. Enter the loss due to the effect of the coupler as external attenuation. You may also perform a non-intrusive test by making the measurement at a test port on the transceiver unit, if available.

CAUTION

If you use the intrusive method, ensure that the power level at the RF input of the spectrum analyzer does not exceed the damage level of 30 dBm.

Measurement Hints

- When setting the input attenuator, the resulting signal level must not be too large or small.
 - If signal power is too high, it can overload the spectrum analyzer and cause ACP.
 - If signal power is too low, the ACP measurement is degraded by the presence of excessive noise.

Set the attenuator to the smallest available value, in dB, that is larger than the transmitter power, in dBm, plus 10 dB.

- Set the reference level so that the displayed signal peak is close to, but does not exceed, the maximum screen display value as follows:
 1. Press **AMPLITUDE**, **Ref Level**, and then enter the value using the numeric keys.
 2. Press **dBm** or **-dBm**.
- Use large resolution bandwidth for fast measurements, and a narrow resolution bandwidth for increased sensitivity.

Making the Measurement

1. Ensure that the base transceiver station microwave transmitter is in service.
2. Connect the device being measured and the spectrum analyzer input as shown in [Figure 4-34](#).

Figure 4-34 Measurement Setup

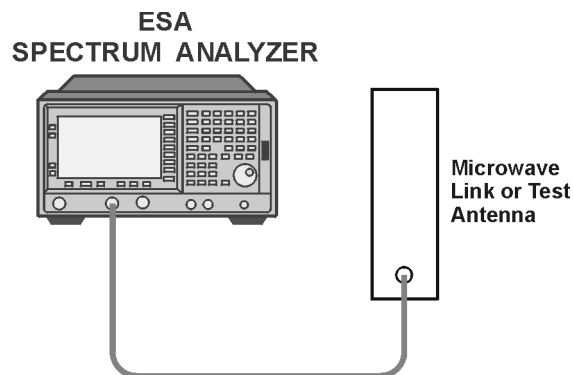

b1721b

3. Set the ESA Spectrum Analyzer to the SA mode by pressing **Mode** and **SA**.
4. Preset the ESA Spectrum Analyzer by pressing **PRESET**.
5. Activate the ACP measurement by pressing **MEASURE** and **ACP**.
6. Set the channel carrier frequency to be measured by pressing **FREQUENCY**, **Center Freq**, and then entering the frequency using the numeric keys.
7. Set the input attenuator as required by pressing **Amplitude**, **Attenuation**, and then entering the value using the numeric keys.
Press **dB**.

NOTE

When setting the input attenuator, the resulting signal level must not be too large or small. For more information, refer to [“Measurement Hints” on page 4-39](#).

8. Set the Main Channel bandwidth to the bandwidth of the modulated channel by pressing **Meas Setup**, **Main Chan BW**, and then enter the bandwidth frequency.
9. Set the integration bandwidth for the selected offset by pressing **Meas Setup**, **Adj Ch BW**, and then enter the integration bandwidth to be used. Normally this is the same value as the bandwidth of the modulated channel set in the previous step.

10. Set the channel spacing for the adjacent channel by pressing **Meas Setup, Chan Spacing**, and then enter the channel spacing frequency.
11. The Lower ACP and Upper ACP are the Adjacent Channel Power values for the selected channel.

Results

Figure 4-35 Example of Adjacent Channel Power Measurement Results

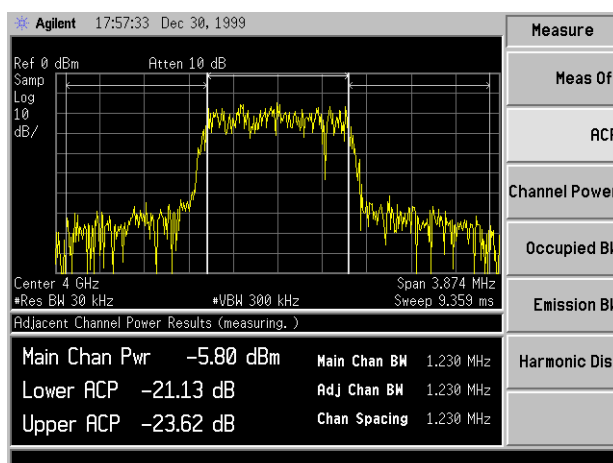

Troubleshooting Hints

- If an external attenuator is used, be sure to include the attenuation value in the measurement. This can be done by entering the **Ref Lvl Offset** under the **AMPLITUDE Y Scale** front panel key.
- If an external preamplifier is used, be sure to include the gain value in the measurement. This can be done by entering the **Ext Amp Gain** under the **AMPLITUDE Y Scale** front panel key.